

CDP-X222ES

SERVICE MANUAL

US Model
Canadian Model
AEP Model
UK Model
E Model
Australian Model

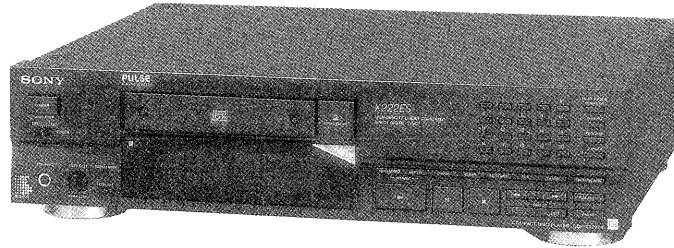

Model Name Using Similar Mechanism	NEW
CD Mechanism Type	CDM-11J-5BD3
Optical Pick-Up Block Type	BU-5BD3

SPECIFICATIONS

Compact disc player

Frequency response	2 Hz — 20 kHz \pm 0.3 dB
Signal to noise ratio	More than 115 dB
Dynamic range	More than 100 dB
Harmonic distortion	Less than 0.0025%
Channel separation	More than 105 dB

Outputs

LINE OUT (FIXED) (phono jacks)	Output level 2 V (at 50 kilohms) Load impedance over 10 kilohms
LINE OUT (VARIABLE) (phone jacks)	Output level max. 2 V (at 50 kilohms) Load impedance over 50 kilohms
DIGITAL OUT (OPTICAL) (optical output connector)	Wave length 660 nm Output level -18 dBm
HEADPHONES (Stereo phone jack)	Output level max. 28 mW Load impedance 32 ohms

General

Power requirements	AEP model 220-230V AC, 50/60Hz UK, Australian model 240V AC, 50/60Hz US, Canadian model 120V AC, 60Hz E model 110-120, 220-240V AC adjustable, 50/60Hz
Power consumption	17 W
Dimensions (approx., including projections)	430×110×340 mm (w/h/d) (17×4 ³ / ₈ ×13 ¹ / ₂ inches)
Weight (approx.)	6.2 kg (13 lbs 11 oz)

—continued on next page—

For the United Kingdom and European countries

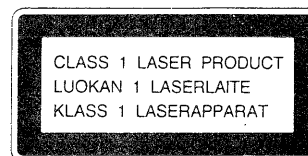

This Compact Disc player is classified as a CLASS 1 LASER product. The CLASS 1 LASER PRODUCT label is located on the rear exterior.

COMPACT DISC PLAYER
SONY[®]



TABLE OF CONTENTS

Remote commander RM-D991

Remote control system	Infrared control
Power requirements	3 V DC with two batteries size AA (IEC designation R6)
Dimensions	62×18×175 mm (w/h/d) (2 1/2×23/32×7 inches)
Weight	130 g (4.6 oz) Including batteries

Supplied accessories

Connecting cord	1 (2 phono plugs ↔ 2 phono plugs)
Remote commander	1
R6 (size AA) batteries	2

Design and specifications subject to change without notice.



<u>Section</u>	<u>Title</u>	<u>Page</u>
1. GENERAL		
	Location of Control	5
2. ELECTRICAL BLOCK CHECKING		6
3. DIAGRAMS		
3-1.	circuit Boards Location.....	8
3-2.	Semiconductor Lead Layouts	8
3-3.	Printed Wiring Boards	9
3-4.	Schematic Diagram.....	13
4. EXPLODED VIEWS		
4-1.	Cabinet	20
4-2.	Front Panel.....	21
4-3.	Chassis	22
4-4.	CD Mechanism Block (CDM11J-5BD3)	23
4-5.	Optical Pick-up Block (BU-5BD3)	24
5. ELECTRICAL PARTS LIST		25

MODEL IDENTIFICATION

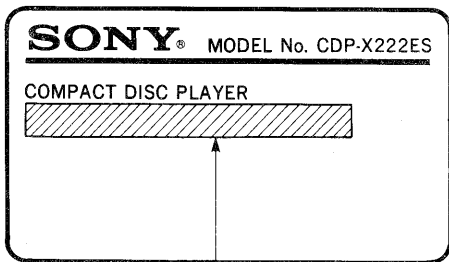
—Model Number Label—



US, Canadian Model: AC: 120V 60Hz 17W
 AEP Model: AC: 220-230V~50Hz
 UK, Australian Model: AC: 240V~50/60Hz
 E, Model: AC: 110-120/220-240V~50/60Hz 17W

SAFETY-RELATED COMPONENT WARNING!!
 COMPONENTS IDENTIFIED BY MARK  OR DOTTED LINE WITH MARK  ON THE SCHEMATIC DIAGRAMS AND IN THE PARTS LIST ARE CRITICAL TO SAFE OPERATION. REPLACE THESE COMPONENTS WITH SONY PARTS WHOSE PART NUMBERS APPEAR AS SHOWN IN THIS MANUAL OR IN SUPPLEMENTS PUBLISHED BY SONY.

ATTENTION AU COMPOSANT AYANT RAPPORT À LA SÉCURITÉ!

LES COMPOSANTS IDENTIFIÉS PAR UNE MARQUE  SUR LES DIAGRAMMES SCHÉMATIQUES ET LA LISTE DES PIÈCES SONT CRITIQUES POUR LA SÉCURITÉ DE FONCTIONNEMENT. NE REMPLACER CES COMPOSANTS QUE PAR DES PIÈCES SONY DONT LES NUMÉROS SONT DONNÉS DANS CE MANUEL OU DANS LES SUPPLÉMENTS PUBLIÉS PAR SONY.

SAFETY CHECK-OUT

After correcting the original service problem, perform the following safety check before releasing the set to the customer:

Check the antenna terminals, metal trim, "metallized" knobs, screws, and all other exposed metal parts for AC leakage. Check leakage as described below.

LEAKAGE TEST

The AC leakage from any exposed metal part to earth ground and from all exposed metal parts to any exposed metal part having a return to chassis, must not exceed 0.5 mA (500 microampers). Leakage current can be measured by any one of three methods.

1. A commercial leakage tester, such as the Simpson 229 or RCA WT-540A. Follow the manufacturers' instructions to use these instruments.
2. A battery-operated AC milliammeter. The Data Precision 245 digital multimeter is suitable for this job.
3. Measuring the voltage drop across a resistor by means of a VOM or battery-operated AC voltmeter. The "limit" indication is 0.75 V, so analog meters must have an accurate low-voltage scale. The Simpson 250 and Sanwa SH-63Trd are examples of a passive VOM that is suitable. Nearly all battery operated digital multimeters that have a 2V AC range are suitable. (See Fig. A)

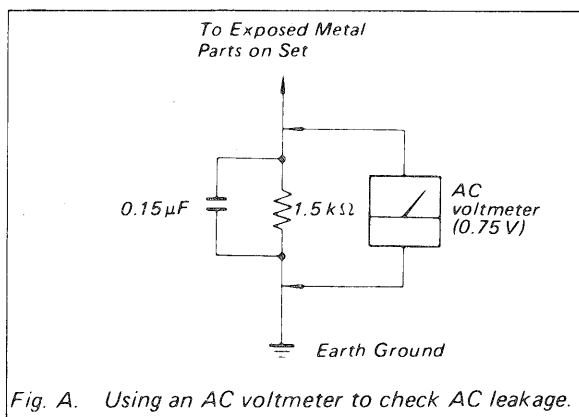

Fig. A. Using an AC voltmeter to check AC leakage.

NOTES ON HANDLING THE OPTICAL PICK-UP BLOCK OR BASE UNIT

The laser diode in the optical pick-up block may suffer electrostatic breakdown because of the potential difference generated by the charged electrostatic load, etc. on clothing and the human body.

During repair, pay attention to electrostatic breakdown and also use the procedure in the printed matter which is included in the repair parts.

The flexible board is easily damaged and should be handled with care.

NOTES ON LASER DIODE EMISSION CHECK

The laser beam on this model is concentrated so as to be focused on the disc reflective surface by the objective lens in the optical pick-up block. Therefore, when checking the laser diode emission, observe from more than 30cm away from the objective lens.

PROTECTION OF EYES FROM LASER BEAM DURING SERVICING

This set employs a laser. Therefore, be sure to follow carefully the instructions below when servicing.

CAUTION

Use of controls or adjustments or performance of procedures other than those specified herein may result in hazardous radiation exposure.

1. Laser Diode Properties

- Material: GaAlAs
- Wavelength: 780 nm
- Emission Duration: continuous
- Laser Output Power: less than 44.6 μ W*
 - * This output is the value measured at a distance of 200 mm from the objective lens surface on the Optical Pick-up Block.

2. During service, do not take the Optical Pick-up Block apart, and do not adjust the APC circuit. If there is a breakdown in the APC circuit (including laser diode), replace the entire Optical Pick-up Block (including APC board).

BESKYTTELSE AF ØJNE MOD LASERSTRÅLING UNDER SERVICE

I dette apparat anvendes laserlys. Derfor skal nedenstående instruktioner nøje følges under service.

Følg igrøvrigt instruktionerne i servicemanualen.

ADVARSEL!!

Under service må øjnene ikke komme nær objektiv-linsen på den optiske pick-up enhed. I tilfælde af at det er nødvendigt at kontrollere udsendelsen af laserlys, skal det ske i en afstand af mere end 25 cm fra den optiske pick-up.

1. Laser-dioe data

- Materiale: GaAlAs
- Bølgelængde: 780 nm
- Udstråling: Kontinuerlig
- Laseroutput: Max. 0,4 mW*
 - * Målt i 1,6 mm afstand fra overfladen af objektiv-linsen på den optiske pick-up enhed.
- Klassifikation: Klasse IIIb.

2. Adskil aldrig den optiske pick-up enhed under service, og juster ikke APC kredsløbet (Automatic Power Control). Hvis APC kredsløbet (incl. laser-dioden) bryder ned, skal hele den optiske pick-up enhed (incl. APC printkortet) udskiftes.

LASER ADVARSEL MÆRKNING

Følgende mærkning findes indvendig i apparatet:

1. Advarsel Mærkning

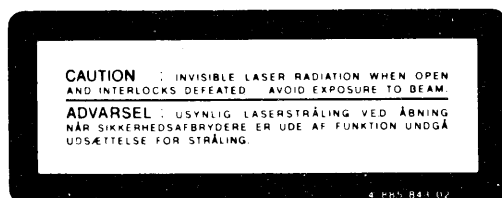

VAROITUS: Laite sisältää, laserdiodin, joka lähettää (näkyvätöntä) silmille vaarallista lasersäteilyä.

SECTION 2 ELECTRICAL BLOCK CHECKING

Note :

1. CD Block basically constructed to operate without adjustment. Therefore, check each item in order given.
2. Use YEDS-18 disc (3-702-101-01) unless otherwise indicated.
3. Use the oscilloscope with more than 10MΩ impedance.
4. Clean an object lens by an applicator with neutral detergent when the signal level is low than specified value with the following checks.

S Curve Check

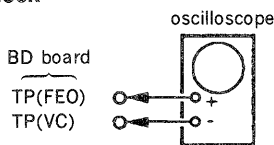

Procedure :

1. Connect oscilloscope to test point TP (FEO) on BD board.
2. Connect between test point TP (FES) and TP (VC) by lead wire.
3. Turned Power switch on and actuate the focus serch. (actuate the focus serch when disc table is moving in and out.)
4. Check the oscilloscope waveform (S curve) is symmetrical between A and B. And confirm peak to peak level within $3 \pm 1V_{p-p}$.

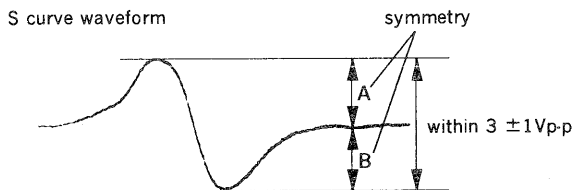

5. After check, remove the lead wire connected in step 2.
- Note :**
- Try to measure several times to make sure that the ratio of A : B or B : A is more than 10 : 7.
 - Take sweep time as long as possible and light up the brightness to obtain best waveform.

RF Level Check

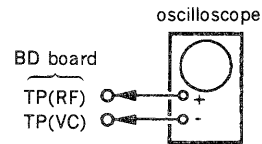

Procedure :

1. Connect oscilloscope to test point TP (RF) on BD board.
2. Turn Power switch on.
3. Put disc (YEDS-18) in and playback.
4. Confirm that oscilloscope waveform is clear and check RF signal level is correct or not.

Note :

Clear RF signal waveform means that the shape "◇" can be clearly distinguished at the center of the waveform.

RF signal waveform

VOLT/DIV: 200mV
TIME/DIV: 500nS

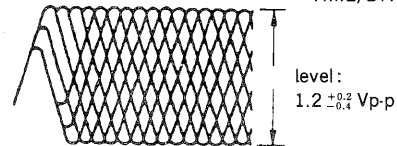

E-F Balance Check

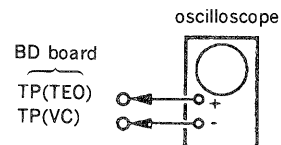

Procedure :

1. Connect test point TP (ADJ) to ground and TP (TES) to TP (VC) with lead wire.
2. Connect oscilloscope to test point TP (TEO) on BD board.
3. Turn Power switch on.
4. Put disc (YEDS-18) in and playback.
5. Confirm that the oscilloscope waveform is symmetrical on the top and bottom in relation to 0V, and check this level.

Traverse oscilloscope

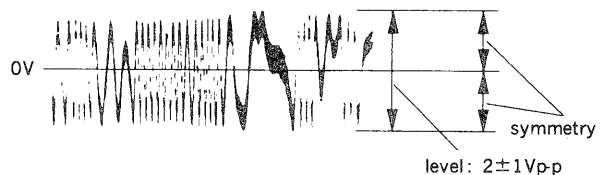

6. Remove the lead wire connected in step 1.

RF PLL Free-run Frequency Check

Procedure :

1. Connect frequency counter to test point (PLCK) with lead wire.

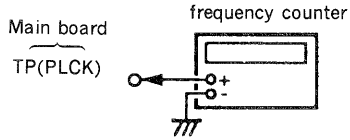

2. Turn Power switch on.
3. Confirm that reading on frequency counter is 4.3218MHz.

Focus/Tracking Gain

This gain has a margin, so even if it is slightly off.

There is no problem.

Therefore, do not perform, this adjustment.

Please note that it should be fixed to mechanical center position when you moved and do not know original position.

Adjustment Locations :

[BD board]

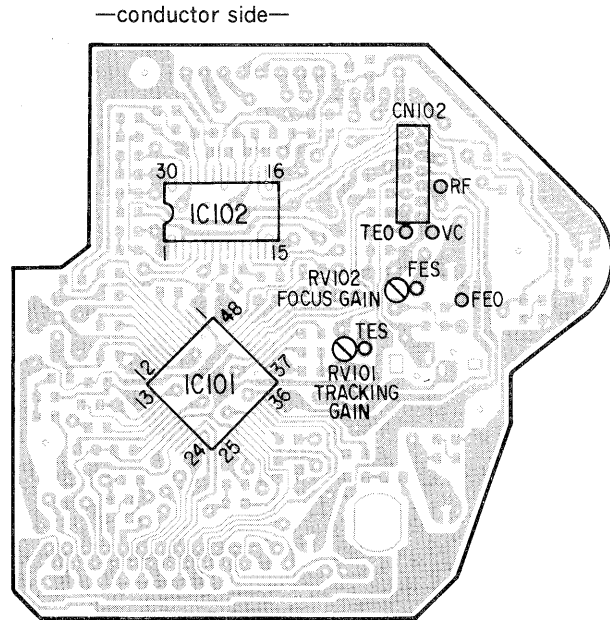

[MAIN board]

-component side-

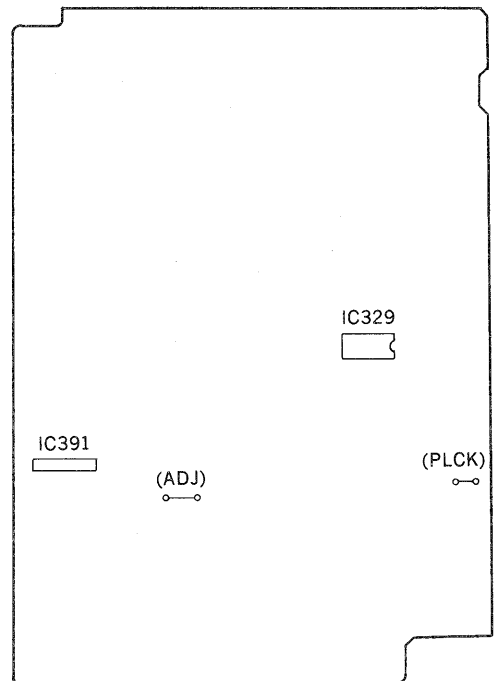

SECTION 3 DIAGRAMS

3-1. CIRCUIT BOARDS LOCATION

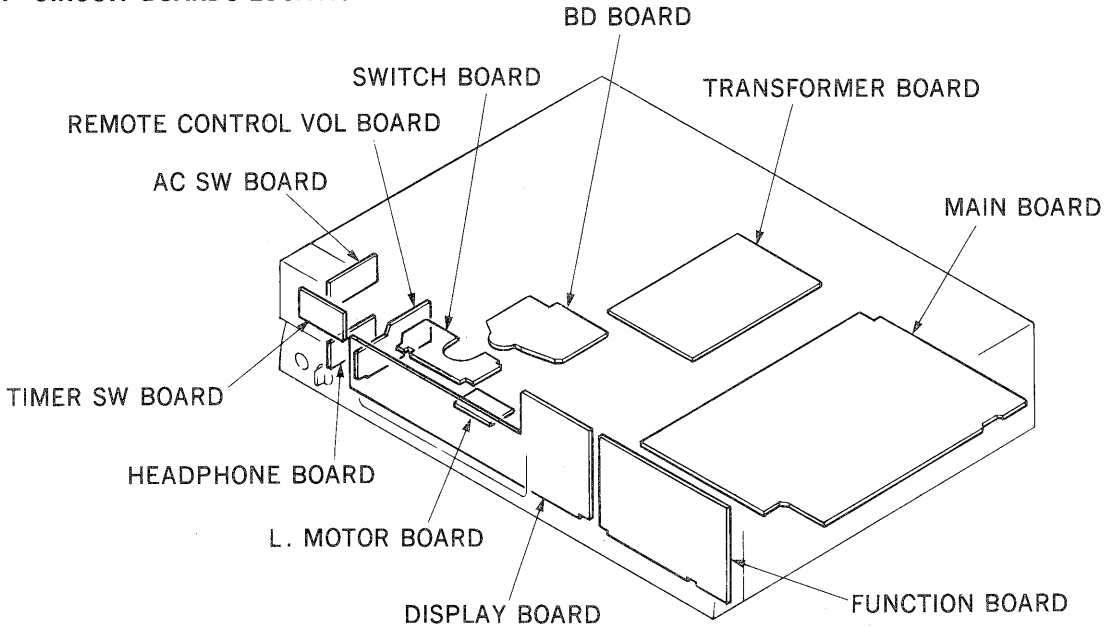

3-2. SEMICONDUCTOR LEAD LAYOUTS

BA6208
M54641L

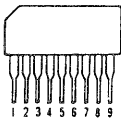

CXD2552Q-3

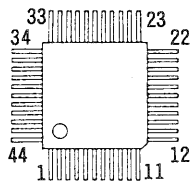

M5290P-16

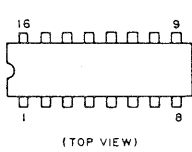

DTC114EF

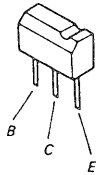

2SC2878-B

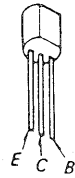

HZS36-3L
RD4.7JSB3
RD5.1ES-B2
RD5.6ES-B2
RD8.2ES-B2
11EQS04
11ES2

cathode

anode

1N4148-M

cathode

anode

BR3371X
MAY3371X-M-177
MBG3371X-14
MBG3371X-177
MPY3371X-177

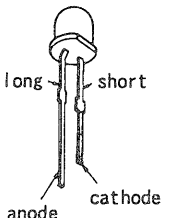

CXA1372Q

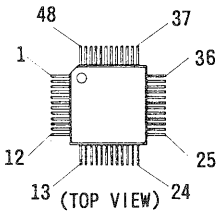

CXD2557M

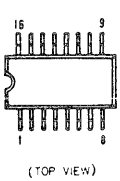

RC4556D
RC5532DD

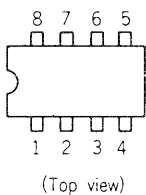

DTC144ES

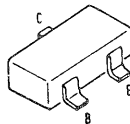

2SD774-34

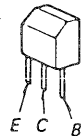

CXD1244S

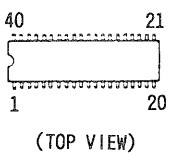

LA6532M

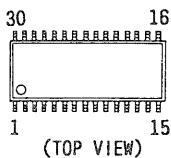

SN74HCU04AN

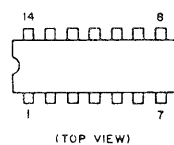

2SB1094L
2SD1944K

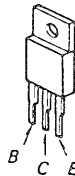

2SK161-GR



CXD2500AQ
MSC62408-015GS-V1K
M37450M8-372FP

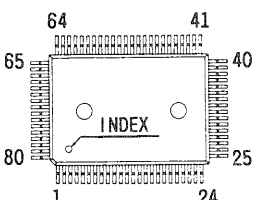

LC3564PML-1015

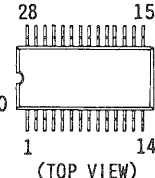

DTA114ES
DTC114ES
DTC143TS



2SC2785-HFE
letter side

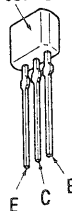

● Semiconductor Location

Ref. No.	Location	Ref. No.	Location
D201	B-7	IC329	F-3
D202	B-5	IC330	F-2
D203	B-6	IC331	E-1
D204	B-6	IC332	C-4
D205	B-6	IC350	A-2
D206	C-5	IC391	G-7
D207	B-4	IC401	I-18
D209	F-7	IC412	G-11
D210	G-4	IC501	E-3
D211	C-7	IC551	C-3
D212	C-6	IC553	B-5
D213	D-6	IC601	E-5
D214	D-4	IC651	C-2
D225	C-7		
D322	D-4	Q101	D-24
D391	H-7	Q204	B-4
D401	D-12	Q206	E-6
D402	D-12	Q207	D-7
D403	C-12	Q208	C-7
D404	D-11	Q209	F-7
D405	D-11	Q210	F-7
D406	I-18	Q217	C-6
D407	I-18	Q218	C-6
D408	C-15	Q223	B-1
D409	C-15	Q323	H-3
D410	C-15	Q401	H-15
D411	D-15	Q402	H-16
D412	A-11	Q403	A-13
D413	G-8	Q404	B-13
D501	D-1	Q405	B-13
D502	E-4	Q406	B-13
D601	D-1	Q407	B-11
D602	E-3	Q408	H-19
		Q501	D-1
IC101	D-23	Q502	B-2
IC102	B-23	Q503	B-3
IC201	D-7	Q504	B-3
IC325	G-5	Q601	E-1
IC326	F-3	Q602	B-2
IC327	H-4	Q603	B-2
IC328	H-2	Q604	B-2

Note:
 ● : parts extracted from the component side.
 ● : Through hole.
 ● : Pattern on the side which is seen.
 ○ : Pattern of the rear side.

3-3. PRINTED WIRING BOARDS ● Refer to page 8 for semiconductor Lead Layouts.

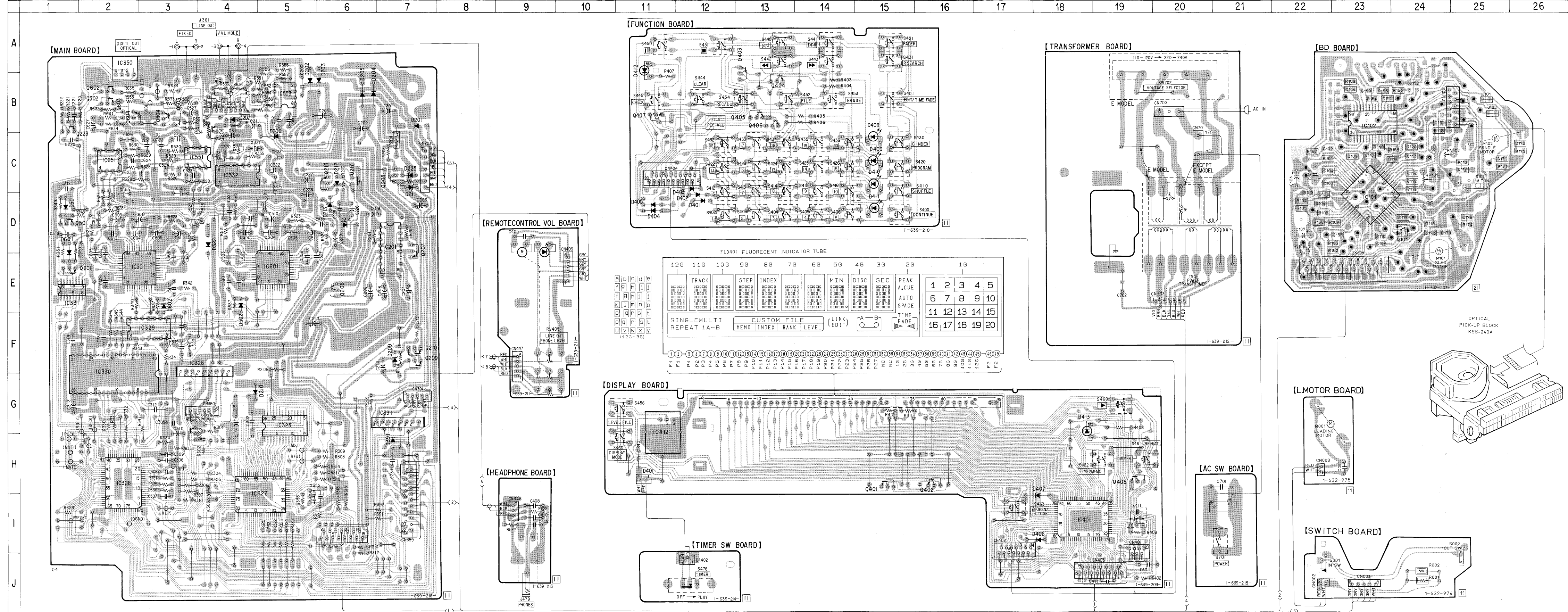

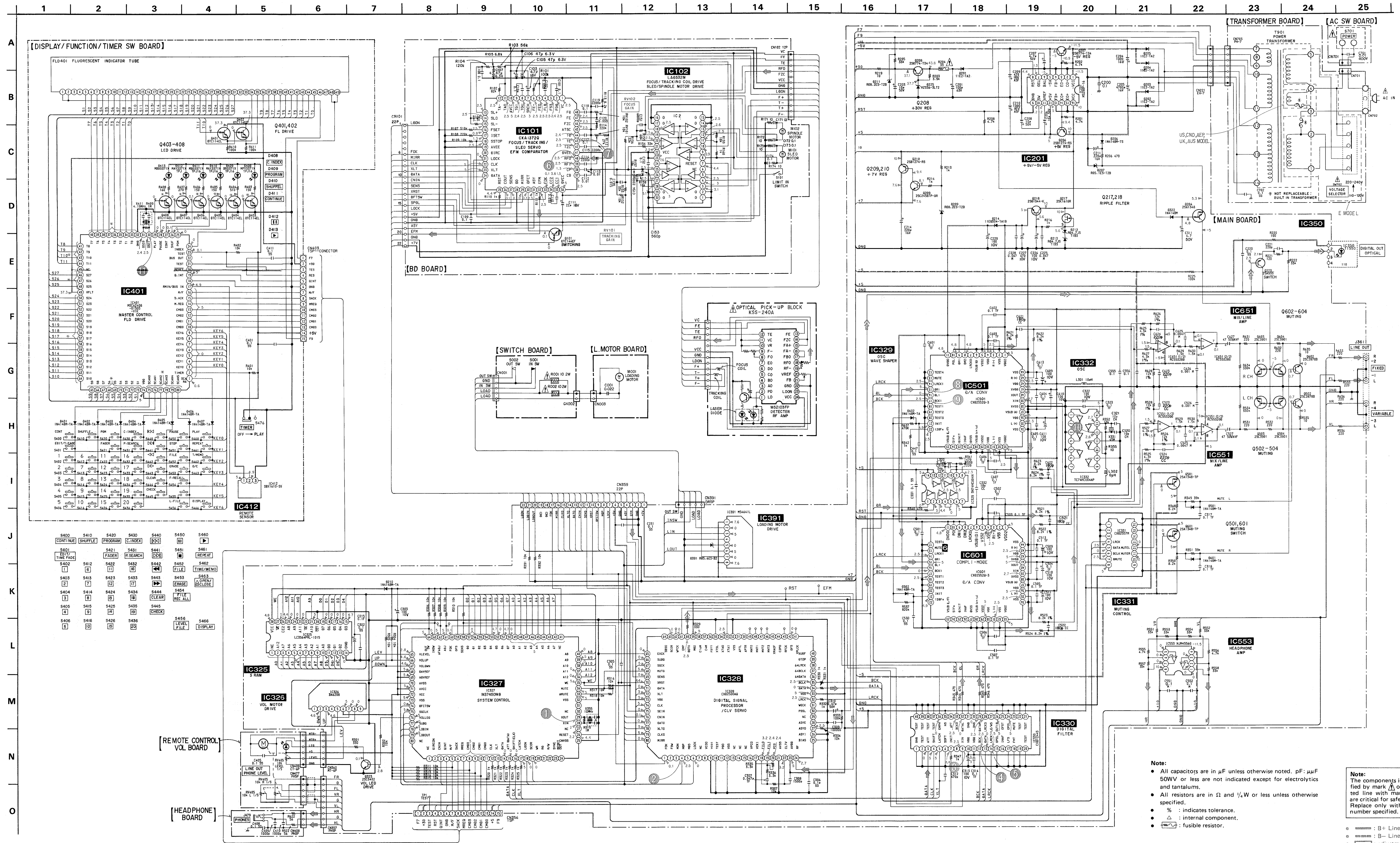

• Wave forms

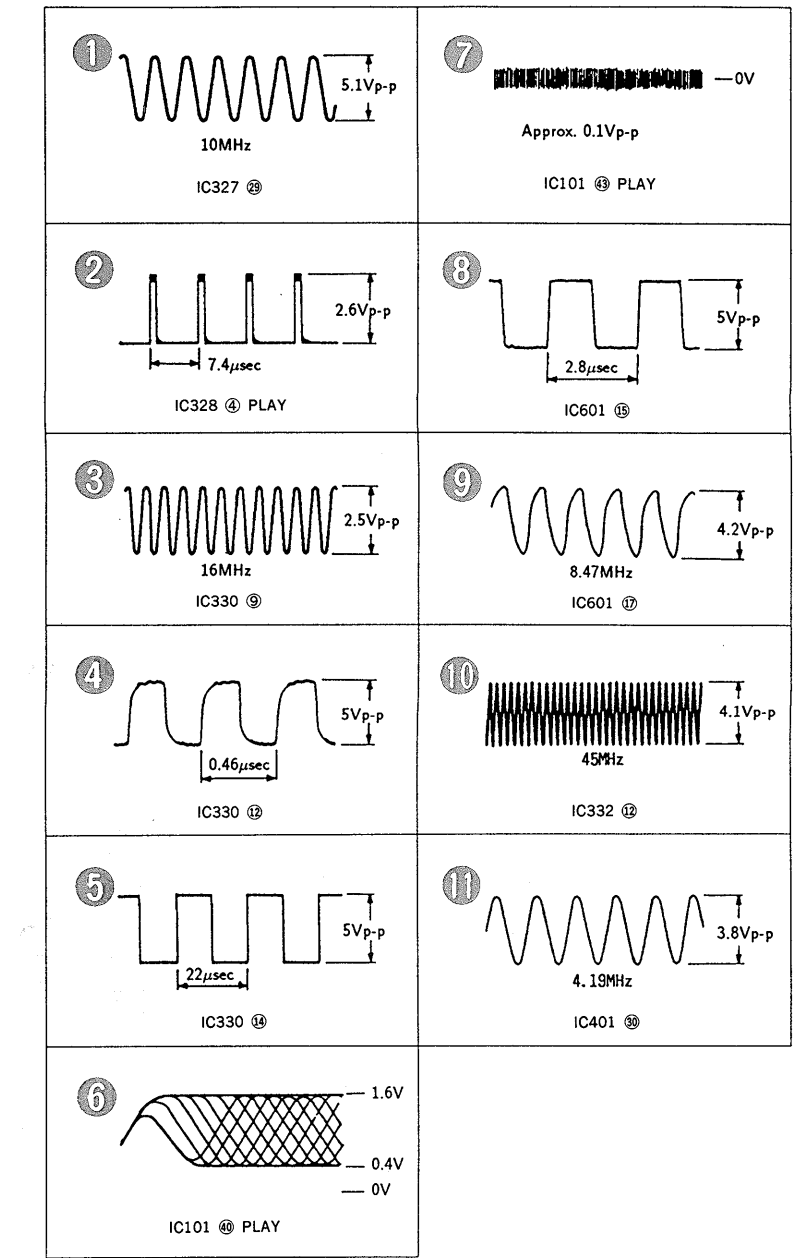

• Fluorescent Indicator Tube Terminal

	12G	11G	10G	9G	8G	7G	6G	5G	4G	3G	2G	1G	
P1	a	a	a	a	a	a	a	a	a	a	a	REPEAT	1
P2	b	b	b	b	b	b	b	b	b	b	b	I	2
P3	c	c	c	c	c	c	c	c	c	c	c	A	3
P4	d	d	d	d	d	d	d	d	d	d	d	B	4
P5	e	e	e	e	e	e	e	e	e	e	e	AC/DC	5
P6	f	f	f	f	f	f	f	f	f	f	f	AUTO SPACE	6
P7	g	g	g	g	g	g	g	g	g	g	g	SINGLE	7
P8	h	h	h	h	h	h	h	h	h	h	h	MULTI	8
P9	i	i	i	i	i	i	i	i	i	i	i	CUSTOM FILE	9
P10	j	j	j	j	j	j	j	j	j	j	j	MEMO	10
P11	k	k	k	k	k	k	k	k	k	k	k	INDEX	11
P12	l	l	l	l	l	l	l	l	l	l	l	BANK	12
P13	m	m	m	m	m	m	m	m	m	m	m	LEVEL	13
P14	n	n	n	n	n	n	n	n	n	n	n	[LINK]	14
P15	o	o	o	o	o	o	o	o	o	o	o	EDIT	15
P16	p	p	p	p	p	p	p	p	p	p	p		16
P17	q	q	q	q	q	q	q	q	q	q	q	A	17
P18	r	r	r	r	r	r	r	r	r	r	r	B	18
P19	s	s	s	s	s	s	s	s	s	s	s	[QD]	19
P20	t	t	t	t	t	t	t	t	t	t	t	TIME	20
P21	u	u	u	u	u	u	u	u	u	u	u		
P22	v	v	v	v	v	v	v	v	v	v	v	[▶]	
P23	w	w	w	w	w	w	w	w	w	w	w	[◀]	
P24	x	x	x	x	x	x	x	x	x	x	x		
P25	y	y	y	y	y	y	y	y	y	y	y		
P26	-	TRACK	-	STEP	-	INDEX	-	MIN	DISC	SEC	PEAK	[▶]	
P27	-	-	-	-	-	-	-	O	-	-	-		

Note:
 • All capacitors are in μF unless otherwise noted. pF : μF
 50WV or less are not indicated except for electrolytics and tantalums.
 • All resistors are in Ω and $\frac{1}{4}\text{W}$ or less unless otherwise specified.
 • % : indicates tolerance.
 • Δ : internal component.
 • \square : fusible resistor.

Note:
 The components identified by mark Δ are critical for safety. Replace only with part number specified.
 Note:
 Les composants identifiés par une marque Δ sont critiques pour la sécurité. Ne les remplacer que par une pièce portant le numéro spécifié.

• Voltage and waveforms are dc with respect to ground under no-signal conditions.
 no mark : STOP
 * : Impossible to measure the voltage at the marked points.
 • Voltages are taken with a VOM (input impedance 10M Ω). Voltage variations may be noted due to normal production tolerances.
 • Waveforms are taken with an oscilloscope. Voltage variations may be noted due to normal production tolerances.
 • Circled numbers refer to waveforms.
 • Signal path. \Rightarrow : CD
 \Rightarrow : digital out

• IC Block Diagrams

IC101 CXA1372Q

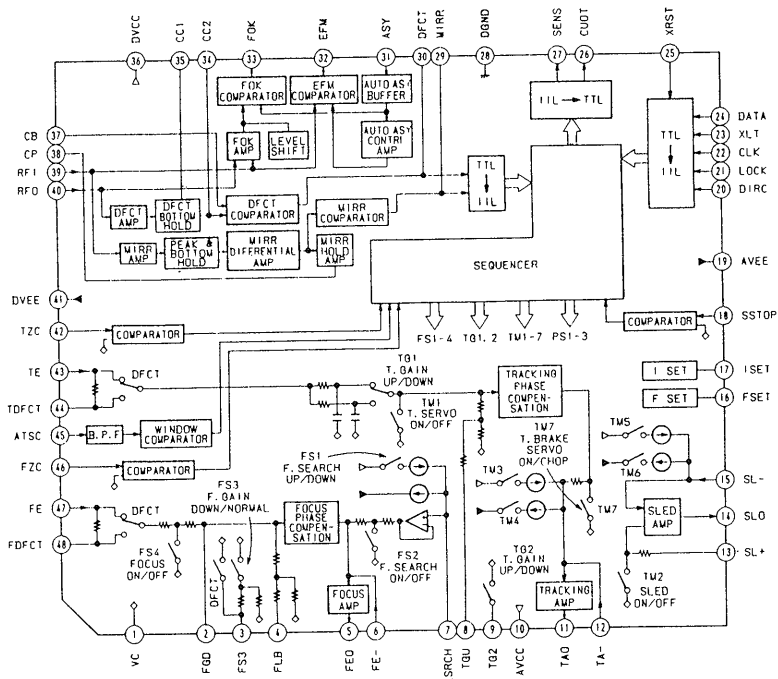

IC501, 601 CXD2552Q-3

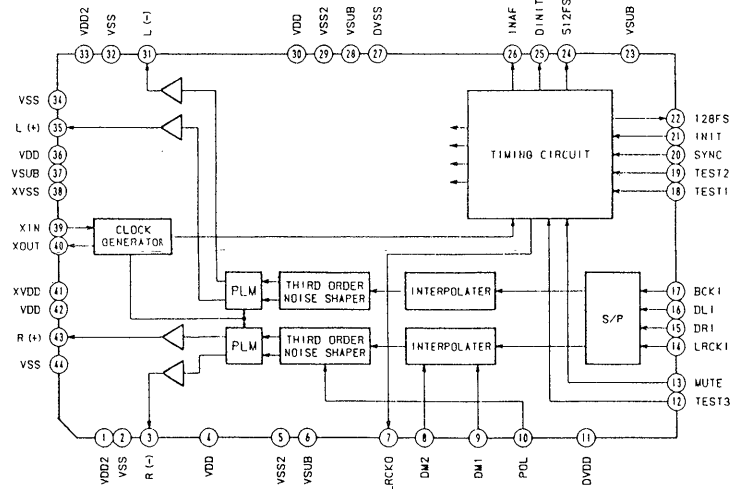

IC328 CXD2500AQ

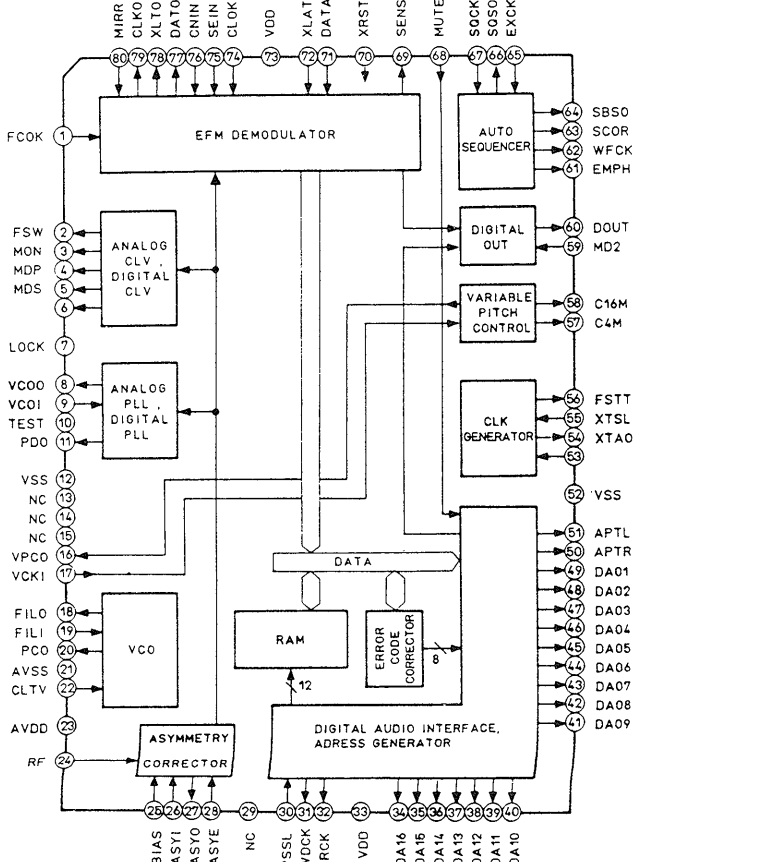

IC331 CDX2557M

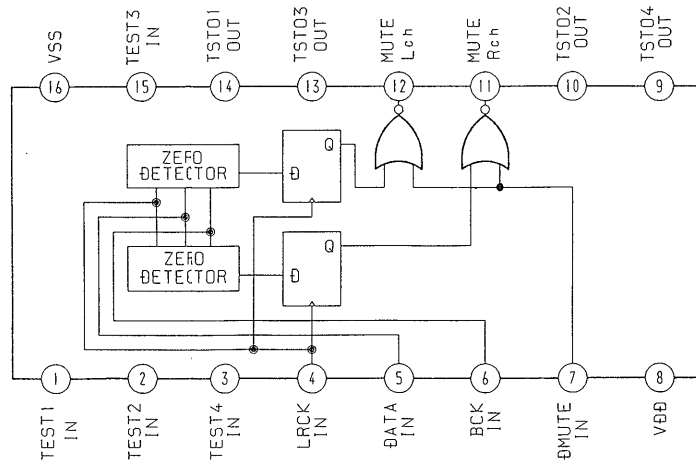

IC362 BA6208

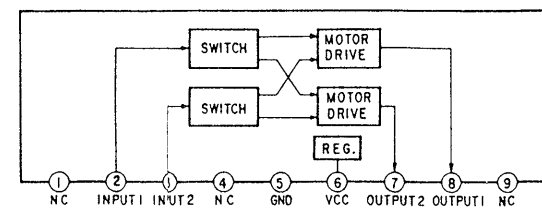

IC330 CXD1244S

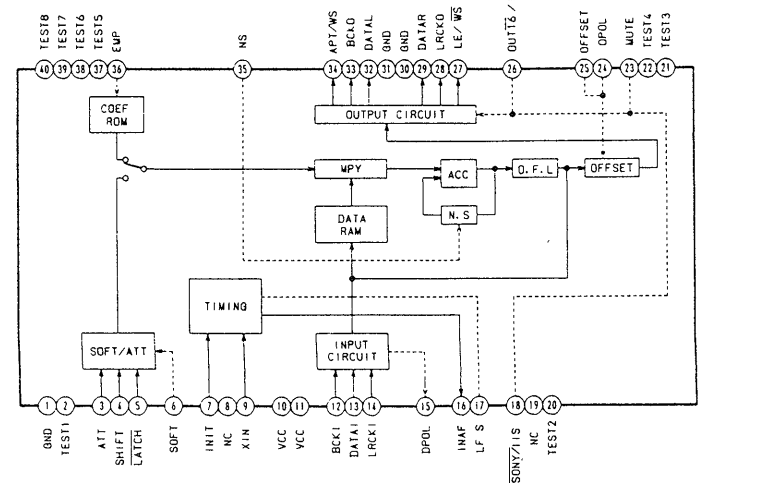

IC201 M5290P

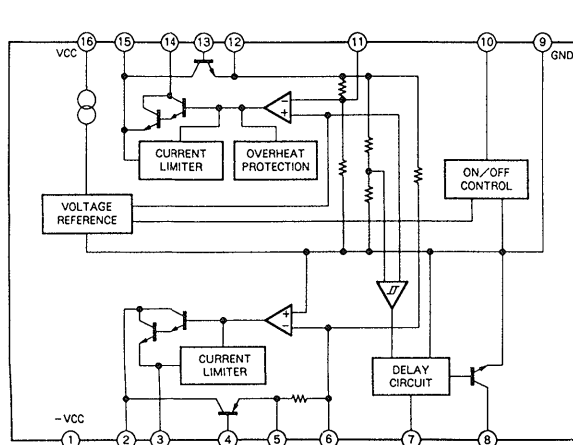

IC391 M54641L

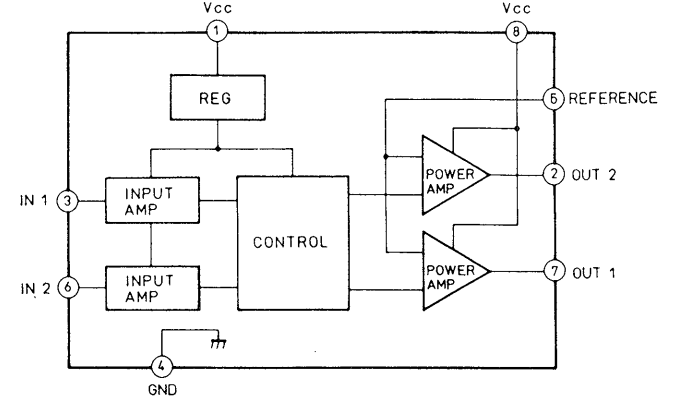

SECTION 4 EXPLODED VIEWS

NOTE:

- The mechanical parts with no reference number in the exploded views are not supplied.
- Items marked "*" are not stocked since they are seldom required for routine service. Some delay should be anticipated when ordering these items.

- -XX, -X mean standardized parts, so they may have some differences from the original one.

- Color Indication of Appearance Parts
Example:

KNOB, BALANCE (WHITE)...(RED)

Parts Color Cabinet's Color

- AUS : Australian model

- Hardware(# mark) list is given in the last of this parts list.

The components identified by mark or dotted line with mark are critical for safety. Replace only with part number specified.

Les composants identifiés par une marque sont critiques pour la sécurité. Ne les remplacer que par une pièce portant le numéro spécifié.

4-1. CABINET

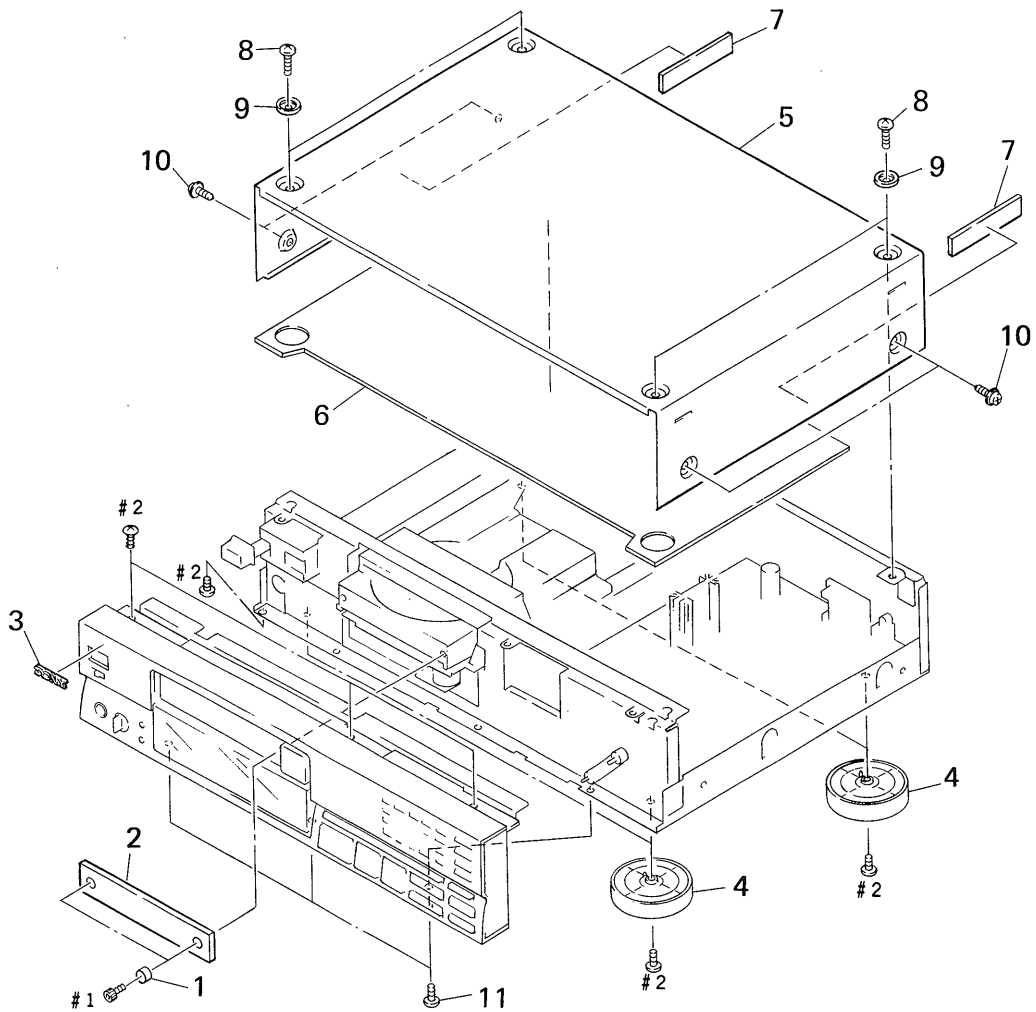

Ref. No.	Part No.	Description	Remark	Ref. No.	Part No.	Description	Remark
1	4-884-635-00	BASE, ORNAMENTAL		7	9-911-845-XX	CUSHION (TOP CASE)	
2	X-4941-212-1	PANEL ASSY, LOADING		8	3-721-187-01	SCREW (3X8)	
3	4-908-848-01	EMBLEM, SONY		9	4-928-025-11	ESCUTCHEON (TOP PLATE)	
4	X-3304-944-1	FOOT ASSY		10	3-704-366-01	SCREW (CASE) (M3X8)	
5	4-934-008-01	CASE		11	3-703-685-21	SCREW (+BV 3X8)	
6	* 4-929-571-01	REINFORCEMENT (CASE)					

4-2. FRONT PANEL

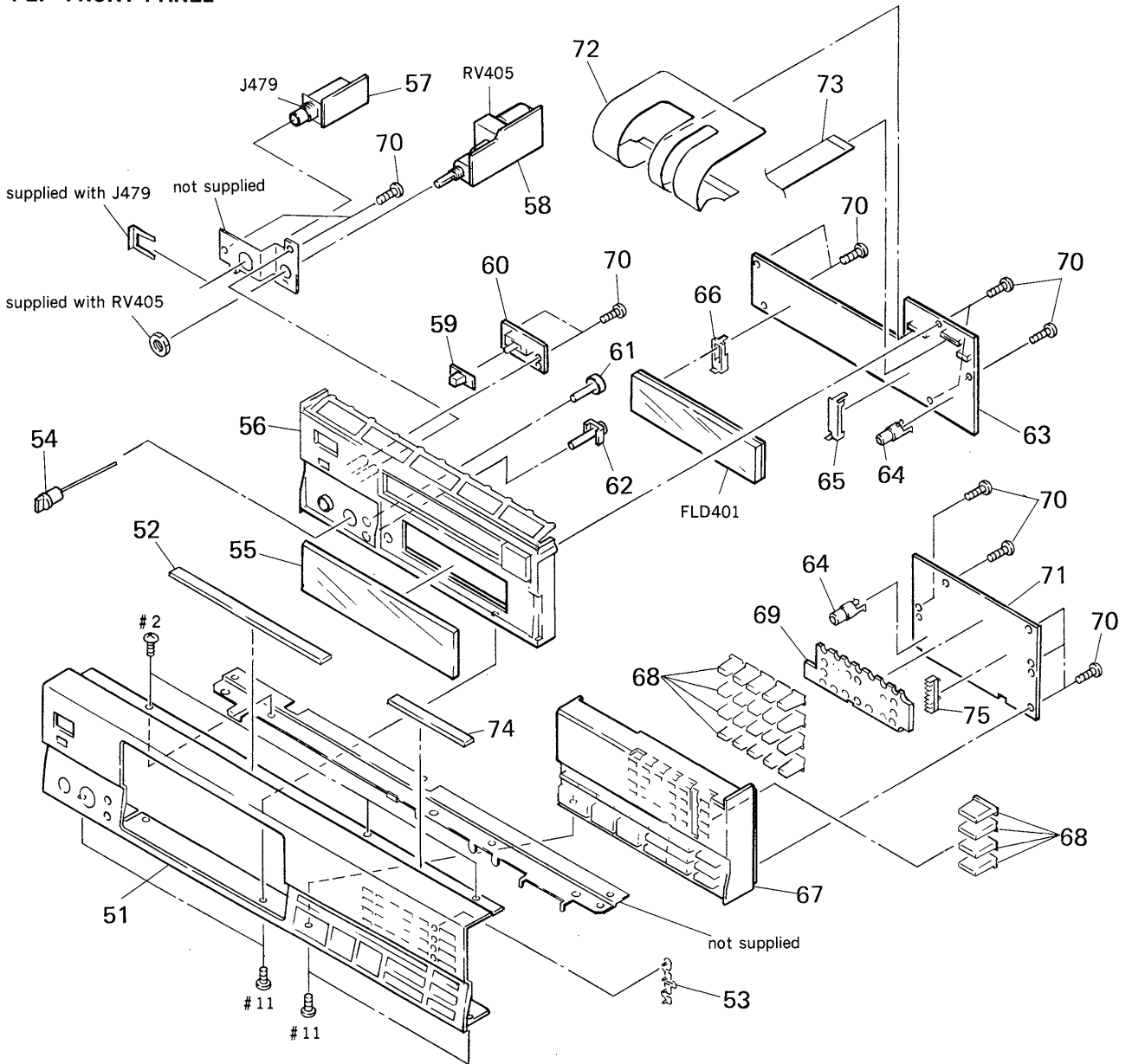



Ref. No.	Part No.	Description	Remark
51	4-944-288-01	PANEL, FRONT (US, UK, AUS, Canadian)	
51	4-944-288-01	PANEL, FRONT (E, AEP)	
52	* 4-929-557-01	CUSHION (PANEL)	
53	4-944-286-01	INDICATOR (MODE)	
54	A-4604-698-A	KNOB (HP) ASSY	
55	4-944-285-02	PLATE, INDICATION	
56	X-4941-491-1	PANEL (L) (SUB) ASSY	
57	* 1-639-213-11	HEADPHONE BOARD	
58	* 1-639-211-11	REMOTE CONTROL VOL BOARD	
59	4-922-518-11	KNOB (TIMER)	
60	* 1-639-214-11	TIMER SW BOARD	
61	4-941-084-01	BUTTON (DISPLAY)	
62	4-941-085-01	BUTTON (LEVEL)	
63	* 1-639-209-11	DISPLAY BOARD	

Ref. No.	Part No.	Description	Remark
64	* 4-941-258-01	HOLDER (LED/PA)	
65	* 4-944-284-01	HOLDER (R)	
66	* 4-944-290-01	HOLDER (L)	
67	X-4941-492-1	PANEL (R) (SUB) ASSY	
68	4-941-079-01	BUTTON (20 KEY)	
69	* 4-944-291-01	CUSHION (20 KEY)	
70	4-928-635-01	SCREW, +BV (2.6X8) TAPPING	
71	* 1-639-210-11	FUNCTION BOARD	
72	1-535-896-11	JUMPER, FILM (WITH TERMINAL)	
73	1-590-882-11	WIRE, FLAT TYPE (15 CORE)	
74	9-911-845-XX	CUSHION (TOP CASE)	
75	* 4-944-289-01	HOLDER (LED/M)	
FLD401	1-519-622-11	INDICATOR TUBE, FLUORESCENT	
J479	1-568-519-41	JACL, LARGE TYPE (PHONES)	
RV405	1-241-321-11	RES, VAR, CARBON 10KX3	

(LINE OUT PHONE LEVEL)

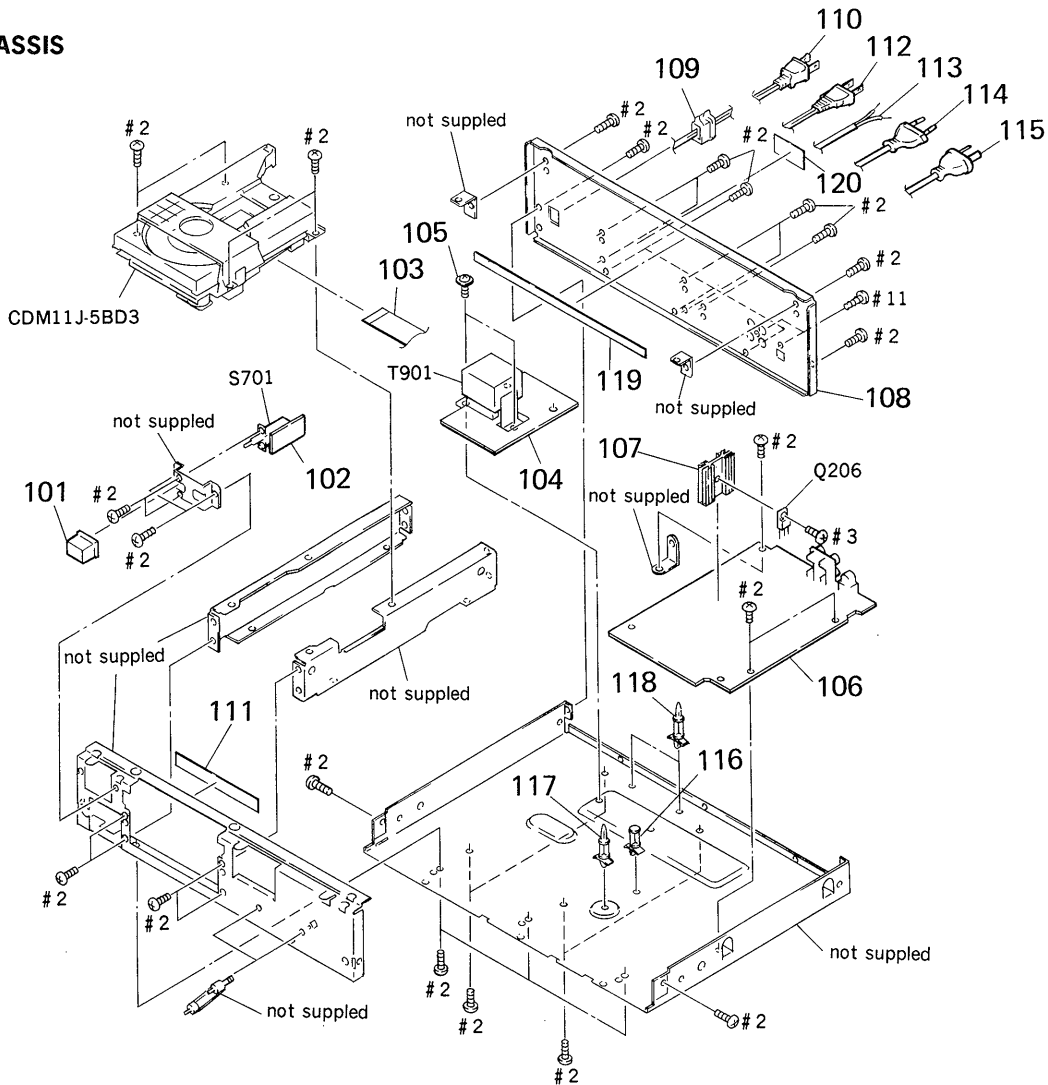







4-3. CHASSIS



Note:
The components identified by mark  or dotted line with mark  are critical for safety. Replace only with part number specified.

Note:
Les composants identifiés par une marque  sont critiques pour la sécurité. Ne les remplacer que par une pièce portant le numéro spécifié.

Ref. No.	Part No.	Description	Remark
101	4-923-520-01	KNOB, POWER	
102	* 1-639-215-11	AC SW BOARD	
103	1-590-883-11	WIRE, FLAT TYPE (22 CORE)	
104	* 1-639-212-11	TRANSFORMER BOARD	
105	4-886-821-11	SCREW, S TIGHT, +PTTWH 3X6	
106	* A-4617-836-A	MAIN BOARD, COMPLETE	
107	* 4-908-502-01	HEAT SINK	
108	* 4-943-715-31	PANEL, BACK (UK)	
108	* 4-943-715-41	PANEL, BACK (E)	
108	* 4-943-715-01	PANEL, BACK (US)	
108	* 4-943-715-11	PANEL, BACK (Canadian)	
108	* 4-943-715-21	PANEL, BACK (AEP)	
108	* 4-943-715-51	PANEL, BACK (AUS)	
109	* 3-703-244-00	BUSHING (2104), CORD	
110	 1-559-583-21	CORD, POWER (US, Canadian)	
111	3-831-441-11	SPACER	

Ref. No.	Part No.	Description	Remark
112	 1-558-181-21	CORD, POWER (E)	
113	 1-559-555-21	CORD, POWER (UK)	
114	 1-558-568-21	CORD, POWER (AEP)	
115	 1-575-379-21	CORD, POWER (AUS)	
116	* 3-349-025-41	HOLDER, PC BOARD	
117	* 4-924-098-01	HOLDER, PC BOARD	
118	* 4-943-687-11	HOLDER, PC BOARD	
119	* 4-927-653-01	SHEET (F/P)	
120	* 4-941-548-01	LABEL, CLASS 1 (AEP, UK, E, AUS)	
Q206	8-729-111-67	TRANSISTOR 2SB1274SA-R	
S701	 1-570-156-11	SWITCH, PUSH (AC 01WER) (1 KEY) (POWER)	
T901	 1-449-921-11	TRANSFORMER, POWER (US, Canadian)	
T901	 1-449-922-11	TRANSFORMER, POWER (UK, AEP, AUS)	
T901	 1-449-923-11	TRANSFORMER, POWER (E)	

4-4. CD MECHANISM BLOCK
(CDM11J-5BD3)

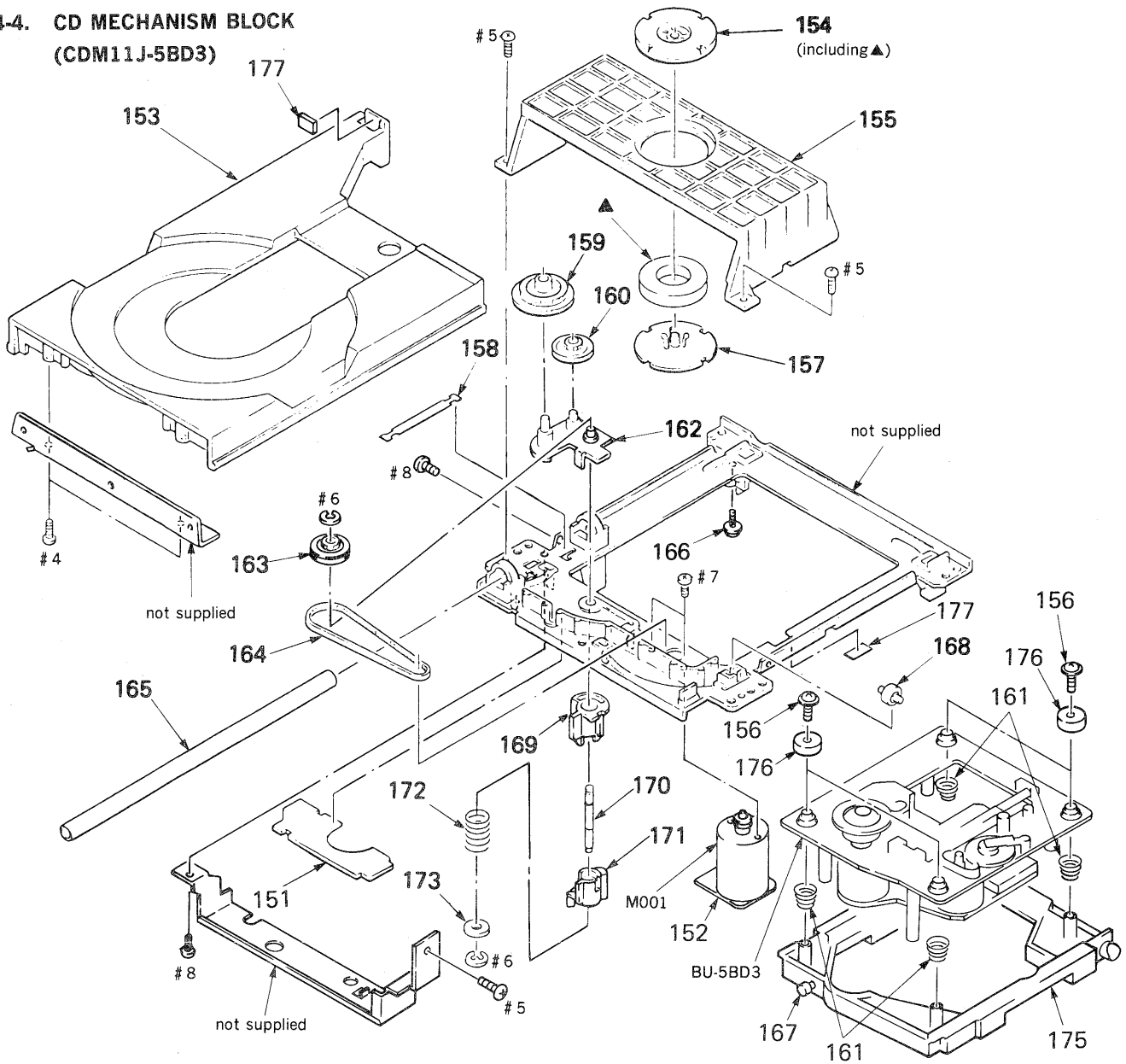

Ref.No.	Part No.	Description	Remark	Ref.No.	Part No.	Description	Remark
151	* 1-632-974-11	SWITCH BOARD		164	4-927-649-01	BELT	
152	* 1-632-975-11	L.MOTOR BOARD		165	4-927-617-01	BAR, GUIDE	
153	* 4-927-642-01	TABLE (EXL), DISK		166	* 4-917-583-21	BRACKET, YOKE	
154	A-4665-024-A	MAGNET ASSY		167	4-927-631-01	ROLLER (L)	
155	* 4-927-638-03	HOLDER (A, P)		168	4-927-627-01	ROLLER (S, G)	
156	4-933-134-01	SCREW (+PTPW M2. 6X6)		169	4-927-624-01	CAM (L, A)	
157	* 4-918-679-04	PULLEY, PRESS		170	4-927-665-01	SHAFT (S)	
158	* 4-927-648-01	SLIDER (GROUND)		171	4-927-635-01	CAM (L, B)	
159	4-927-620-01	GEAR (P)		172	3-659-338-00	SPRING, COMPRESSION	
160	4-927-628-01	GEAR (C)		173	4-927-654-01	WASHER (LIMITER)	
161	4-917-541-01	SPRING (B)		174	* 4-927-670-01	CUSHION (MD)	
162	X-4927-608-1	ARM ASSY, SWING		175	4-943-118-01	HOLDER (BD)	
163	4-929-724-01	PULLEY (B)		176	4-943-119-01	HOLDER (SP)	
				177	3-831-441-XX	CUSHION	
				M001	A-4604-347-A	MOTOR (L) ASSY	

4-5. OPTICAL PICK-UP BLOCK
(BU-5BD3)

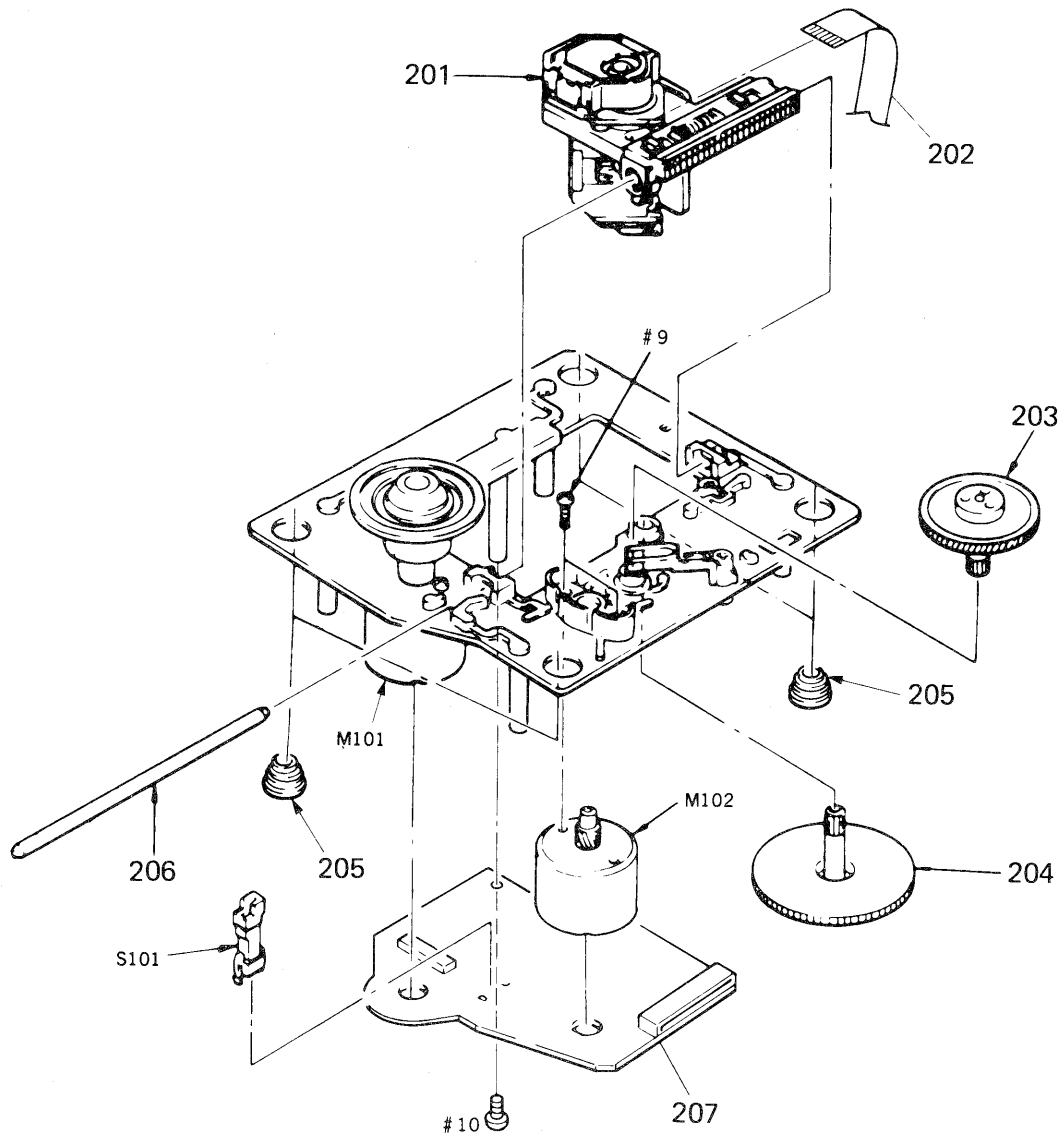

Ref. No.	Part No.	Description	Remark	Ref. No.	Part No.	Description	Remark
201	8-848-144-11	DEVICE, OPTICAL KSS-240A		206	4-917-565-01	SHAFT, SLED	
202	1-575-001-11	WIRE, FLAT TYPE (12 CORE)		207	* A-4617-371-A	BD BOARD, COMPLETE	
203	4-917-567-01	GEAR (M)		M101	X-4917-523-3	MOTOR ASSY (SPINDLE)	
204	4-917-564-01	GEAR (P), FLATNESS		M102	X-4917-504-1	MOTOR ASSY (SLED)	
205	4-933-126-01	INSULATOR (A)		S101	1-572-085-11	SWITCH, LEAF (LIMIT IN)	

SECTION 5
ELECTRICAL PARTS LIST

BD

NOTE:

- Due to standardization, replacements in the parts list may be different from the parts specified in the diagrams or the components used on the set.
- Items marked "*" are not stocked since they are seldom required for routine service. Some delay should be anticipated when ordering these items.
- -XX, -X mean standardized parts, so they may have some differences from the original one.
- CAPACITORS
uF: μ F

- RESISTORS
All resistors are in ohms
METAL: Metal-film resistor
METAL OXIDE: Metal Oxide-film resistor
F: nonflammable
- COILS
uH: μ H
- SEMICONDUCTORS
In each case, u: μ , for example:
uA...: μ A..., uPA...: μ PA...,
uPB...: μ PB..., uPC...: μ PC...,
uPD...: μ PD...
- AUS : Australian model

The components identified by mark Δ or dotted line with mark Δ are critical for safety. Replace only with part number specified.

Les composants identifiés par une marque Δ sont critiques pour la sécurité. Ne les remplacer que par une pièce portant le numéro spécifié.

When indicating parts by reference number, please include the board name.

Ref. No.	Part No.	Description	Remark	Ref. No.	Part No.	Description	Remark
	* A-4617-371-A	BD BOARD, COMPLETE *****				< CONNECTOR >	
		< CAPACITOR >				< IC >	
C101	1-163-038-00	CERAMIC CHIP	0.1uF 25V	CN101	1-568-796-11	SOCKET, CONNECTOR 22P	
C102	1-163-989-11	CERAMIC CHIP	0.033uF 10% 25V	CN102	1-568-795-11	SOCKET, CONNECTOR 12P	
C103	1-126-163-11	ELECT	4.7uF 20% 50V			< IC >	
C104	1-163-038-00	CERAMIC CHIP	0.1uF 25V	IC101	8-752-050-82	IC CXA1372Q	
C105	1-126-154-11	ELECT	47uF 20% 6.3V	IC102	8-759-821-49	IC LA6532M	
C106	1-126-154-11	ELECT	47uF 20% 6.3V			< JUMPER >	
C107	1-126-154-11	ELECT	47uF 20% 6.3V	J101	1-216-295-00	METAL CHIP 0 5% 1/10W	
C108	1-163-038-00	CERAMIC CHIP	0.1uF 25V	J102	1-216-295-00	METAL CHIP 0 5% 1/10W	
C109	1-163-038-00	CERAMIC CHIP	0.1uF 25V			< TRANSISTOR >	
C110	1-163-989-11	CERAMIC CHIP	0.033uF 10% 25V	Q101	8-729-901-01	TRANSISTOR DTC144EK	
C111	1-131-367-00	TANTALUM	22uF 10% 20V			< RESISTOR >	
C112	1-164-232-11	CERAMIC CHIP	0.01uF 50V	R101	1-216-097-00	METAL CHIP 100K 5% 1/10W	
C113	1-164-232-11	CERAMIC CHIP	0.01uF 50V	R102	1-216-095-00	METAL CHIP 82K 5% 1/10W	
C114	1-164-161-11	CERAMIC CHIP	0.0022uF 10% 100V	R103	1-216-091-00	METAL CHIP 56K 5% 1/10W	
C115	1-164-161-11	CERAMIC CHIP	0.0022uF 10% 100V	R104	1-216-099-00	METAL CHIP 120K 5% 1/10W	
C117	1-163-038-00	CERAMIC CHIP	0.1uF 25V	R105	1-216-069-00	METAL CHIP 6.8K 5% 1/10W	
C118	1-163-038-00	CERAMIC CHIP	0.1uF 25V	R106	1-216-061-00	METAL CHIP 3.3K 5% 1/10W	
C119	1-164-161-11	CERAMIC CHIP	0.0022uF 10% 100V	R107	1-216-114-00	METAL GLAZE 510K 5% 1/10W	
C120	1-163-989-11	CERAMIC CHIP	0.033uF 10% 25V	R108	1-216-105-00	METAL CHIP 220K 5% 1/10W	
C151	1-163-019-00	CERAMIC CHIP	0.0068uF 10% 50V	R109	1-216-061-00	METAL CHIP 3.3K 5% 1/10W	
C152	1-163-038-00	CERAMIC CHIP	0.1uF 25V	R110	1-216-049-00	METAL CHIP 1K 5% 1/10W	
C153	1-163-006-11	CERAMIC CHIP	560PF 10% 50V	R111	1-216-049-00	METAL CHIP 1K 5% 1/10W	
C154	1-164-161-11	CERAMIC CHIP	0.0022uF 10% 100V	R112	1-216-083-00	METAL CHIP 27K 5% 1/10W	
C155	1-163-023-00	CERAMIC CHIP	0.015uF 5% 50V	R113	1-216-071-00	METAL CHIP 8.2K 5% 1/10W	
C171	1-163-038-00	CERAMIC CHIP	0.1uF 25V	R114	1-216-105-00	METAL CHIP 220K 5% 1/10W	
C172	1-163-038-00	CERAMIC CHIP	0.1uF 25V	R152	1-216-073-00	METAL CHIP 10K 5% 1/10W	
C173	1-163-038-00	CERAMIC CHIP	0.1uF 25V	R153	1-216-085-00	METAL CHIP 33K 5% 1/10W	
C174	1-163-038-00	CERAMIC CHIP	0.1uF 25V				

BD DISPLAY FUNCTION

Ref. No.	Part No.	Description	Remark
R154	1-216-085-00	METAL CHIP 33K	5% 1/10W
R155	1-216-093-00	METAL CHIP 68K	5% 1/10W
R156	1-216-081-00	METAL CHIP 22K	5% 1/10W
R157	1-216-079-00	METAL CHIP 18K	5% 1/10W
R158	1-216-079-00	METAL CHIP 18K	5% 1/10W
R159	1-216-079-00	METAL CHIP 18K	5% 1/10W
R160	1-216-049-00	METAL CHIP 1K	5% 1/10W
R171	1-216-001-00	METAL CHIP 10	5% 1/10W
R172	1-216-001-00	METAL CHIP 10	5% 1/10W
R173	1-216-001-00	METAL CHIP 10	5% 1/10W
R174	1-216-001-00	METAL CHIP 10	5% 1/10W
< VARIABLE RESISTOR >			
RV101	1-238-016-11	RES. ADJ. CARBON 10K	
RV102	1-238-016-11	RES. ADJ. CARBON 10K	
< SWITCH >			
S101	1-572-085-11	SWITCH, LEAF (LIMIT IN)	

* 1-639-209-11 DISPLAY BOARD			

* 4-941-258-01 HOLDER (LED/PA)			
* 4-944-284-01 HOLDER (R)			
* 4-944-290-01 HOLDER (L)			
< CAPACITOR >			
C411	1-164-159-11	CERAMIC 0.1uF	50V
< CONNECTOR >			
CN403	* 1-568-834-11	SOCKET, CONNECTOR 15P	
CN406	* 1-580-470-11	SOCKET, CONNECTOR 7P	
CN407	* 1-569-511-11	SOCKET, CONNECTOR 14P	
< DIODE >			
D406	8-719-987-63	DIODE 1N4148M	
D407	8-719-987-63	DIODE 1N4148M	
D413	8-719-987-XX	DIODE MBG3371X-14	
< FLUORESCENT INDICATOR >			
FLD401	1-519-622-11	INDICATOR TUBE, FLUORESCENT	
< IC >			
IC401	8-759-505-50	IC MSC62408-015GS-V1K	
IC412	8-749-922-36	IC GP1U50XB	

Ref. No.	Part No.	Description	Remark
< TRANSISTOR >			
Q401	8-729-900-45	TRANSISTOR DTC114EF	
Q402	8-729-900-45	TRANSISTOR DTC114EF	
Q408	8-729-900-45	TRANSISTOR DTC114EF	
< RESISTOR >			
R401	1-249-429-11	CARBON 10K	5% 1/4W
R402	1-249-429-11	CARBON 10K	5% 1/4W
R408	1-247-812-11	CARBON 160	5% 1/4W
R409	1-247-903-00	CARBON 1M	5% 1/4W
R410	1-249-441-11	CARBON 100K	5% 1/4W
R411	1-249-441-11	CARBON 100K	5% 1/4W
< SWITCH >			
S456	1-554-303-21	SWITCH, KEY BOARD (LEVEL FILE)	
S460	1-554-303-21	SWITCH, KEY BOARD (▶)	
S461	1-554-303-21	SWITCH, KEY BOARD (REPEAT)	
S462	1-554-303-21	SWITCH, KEY BOARD (TIME/MEMO)	
S463	1-554-303-21	SWITCH, KEY BOARD (OPEN/CLOSE)	
S464	1-554-303-21	SWITCH, KEY BOARD (DISPLAY)	
< CERAMIC >			
X411	1-577-101-11	VIBRATOR, CERAMIC (4.19MHz)	

* 1-639-210-11 FUNCTION BOARD			

* 4-941-258-01 HOLDER (LED/PA)			
* 4-944-289-01 HOLDER (LED/M)			
< CONNECTOR >			
CN404	* 1-580-462-11	SOCKET, CONNECTOR 20P	
< DIODE >			
D401	8-719-987-63	DIODE 1N4148M	
D402	8-719-987-63	DIODE 1N4148M	
D403	8-719-987-63	DIODE 1N4148M	
D404	8-719-987-63	DIODE 1N4148M	
D405	8-719-987-63	DIODE 1N4148M	
D408	8-719-970-98	DIODE MPY3371X-177	
D409	8-719-987-97	DIODE BR3371X	
D410	8-719-971-52	DIODE MAY3371X-M-177	
D411	8-719-971-50	DIODE MBG3371X-177	
D412	8-719-971-52	DIODE MAY3371X-M-177	

FUNCTION

HEADPHONE

MAIN

Ref. No.	Part No.	Description	Remark
< TRANSISTOR >			
Q403	8-729-900-45	TRANSISTOR DTC114EF	
Q404	8-729-900-45	TRANSISTOR DTC114EF	
Q405	8-729-900-45	TRANSISTOR DTC114EF	
Q406	8-729-900-45	TRANSISTOR DTC114EF	
Q407	8-729-900-45	TRANSISTOR DTC114EF	
< RESISTOR >			
R403	1-249-407-11	CARBON 150 5% 1/4W	
R404	1-249-442-11	CARBON 510 5% 1/4W	
R405	1-249-407-11	CARBON 150 5% 1/4W	
R406	1-249-407-11	CARBON 150 5% 1/4W	
R407	1-249-410-11	CARBON 270 5% 1/4W	
< SWITCH >			
S400	1-554-303-21	SWITCH, KEY BOARD (CONTINUE)	
S401	1-554-303-21	SWITCH, KEY BOARD (EDIT/TIME FADE)	
S402	1-554-303-21	SWITCH, KEY BOARD (1)	
S403	1-554-303-21	SWITCH, KEY BOARD (2)	
S404	1-554-303-21	SWITCH, KEY BOARD (3)	
S405	1-554-303-21	SWITCH, KEY BOARD (4)	
S406	1-554-303-21	SWITCH, KEY BOARD (5)	
S410	1-554-303-21	SWITCH, KEY BOARD (SHUFFLE)	
S412	1-554-303-21	SWITCH, KEY BOARD (6)	
S413	1-554-303-21	SWITCH, KEY BOARD (7)	
S414	1-554-303-21	SWITCH, KEY BOARD (8)	
S415	1-554-303-21	SWITCH, KEY BOARD (9)	
S416	1-554-303-21	SWITCH, KEY BOARD (10)	
S420	1-554-303-21	SWITCH, KEY BOARD (PROGRAM)	
S421	1-554-303-21	SWITCH, KEY BOARD (FADER)	
S422	1-554-303-21	SWITCH, KEY BOARD (11)	
S423	1-554-303-21	SWITCH, KEY BOARD (12)	
S424	1-554-303-21	SWITCH, KEY BOARD (13)	
S425	1-554-303-21	SWITCH, KEY BOARD (14)	
S426	1-554-303-21	SWITCH, KEY BOARD (15)	
S430	1-554-303-21	SWITCH, KEY BOARD (C. INDEX)	
S431	1-554-303-21	SWITCH, KEY BOARD (P. SEARCH)	
S432	1-554-303-21	SWITCH, KEY BOARD (16)	
S433	1-554-303-21	SWITCH, KEY BOARD (17)	
S434	1-554-303-21	SWITCH, KEY BOARD (18)	
S435	1-554-303-21	SWITCH, KEY BOARD (19)	
S436	1-554-303-21	SWITCH, KEY BOARD (20)	
S440	1-554-303-21	SWITCH, KEY BOARD (⏪)	
S441	1-554-303-21	SWITCH, KEY BOARD (⏩)	
S442	1-554-303-21	SWITCH, KEY BOARD (◀)	
S443	1-554-303-21	SWITCH, KEY BOARD (▶)	
S444	1-554-303-21	SWITCH, KEY BOARD (CLEAR)	
S445	1-554-303-21	SWITCH, KEY BOARD (CHECK)	
S450	1-554-303-21	SWITCH, KEY BOARD (■)	

Ref. No.	Part No.	Description	Remark
S451	1-554-303-21	SWITCH, KEY BOARD (■)	
S452	1-554-303-21	SWITCH, KEY BOARD (FILE)	
S453	1-554-303-21	SWITCH, KEY BOARD (ERASE)	
S454	1-554-303-21	SWITCH, KEY BOARD (FILE RECALL)	

* 1-639-213-11 HEADPHONE BOARD			

< CAPACITOR >			
C408	1-164-159-11	CERAMIC 0.1uF 50V	
C409	1-162-294-31	CERAMIC 0.001uF 10% 50V	
C410	1-162-294-31	CERAMIC 0.001uF 10% 50V	
< CONNECTOR >			
CN408	* 1-564-719-11	PIN, CONNECTOR (SMALL TYPE) 3P	
< JACK >			
J479	1-568-519-41	JACK, LARGE TYPE (PHONES)	
< RESISTOR >			
R522	1-249-402-11	CARBON 56 5% 1/4W	
R622	1-249-402-11	CARBON 56 5% 1/4W	

* A-4617-836-A MAIN BOARD, COMPLETE			

* 4-908-502-01 HEAT SINK			
7-682-548-04 SCREW +BVTT 3X8 (S)			
< CAPACITOR >			
C200	1-164-159-11	CERAMIC 0.1uF 50V	
C201	1-124-572-11	ELECT 100uF 20% 63V	
C203	1-126-059-11	ELECT 10uF 20% 50V	
C204	1-126-013-11	ELECT 1000uF 20% 16V	
C205	1-126-016-11	ELECT 4700uF 20% 16V	
C206	1-126-059-11	ELECT 10uF 20% 50V	
C207	1-126-163-11	ELECT 4.7uF 20% 50V	
C208	1-126-059-11	ELECT 10uF 20% 50V	
C209	1-126-012-11	ELECT 470uF 20% 16V	
C210	1-126-013-11	ELECT 1000uF 20% 16V	
C211	1-126-024-11	ELECT 220uF 20% 16V	
C214	1-126-024-11	ELECT 220uF 20% 16V	
C215	1-125-622-11	DOUBLE LAYERS 0.10F	
C220	1-164-159-11	CERAMIC 0.1uF 50V	
C221	1-162-286-31	CERAMIC 220PF 10% 50V	

MAIN

Ref. No.	Part No.	Description	Remark	Ref. No.	Part No.	Description	Remark
C225	1-130-491-00	MYLAR 0.047uF	5% 50V	C555	1-136-165-00	FILM 0.1uF	5% 50V
C226	1-124-994-11	ELECT 100uF	20% 10V	C556	1-136-165-00	FILM 0.1uF	5% 50V
C227	1-124-997-11	ELECT 470uF	20% 10V	C601	1-136-165-00	FILM 0.1uF	5% 50V
C228	1-130-491-00	MYLAR 0.047uF	5% 50V	C602	1-136-165-00	FILM 0.1uF	5% 50V
C229	1-124-994-11	ELECT 100uF	20% 10V	C603	1-136-165-00	FILM 0.1uF	5% 50V
C231	1-164-159-11	CERAMIC 0.1uF	50V	C604	1-162-806-11	CERAMIC 0.1uF	10% 50V
C302	1-164-159-11	CERAMIC 0.1uF	50V	C605	1-136-165-00	FILM 0.1uF	5% 50V
C303	1-124-994-11	ELECT 100uF	20% 10V	C606	1-136-165-00	FILM 0.1uF	5% 50V
C305	1-164-159-11	CERAMIC 0.1uF	50V	C607	1-136-165-00	FILM 0.1uF	5% 50V
C306	1-164-159-11	CERAMIC 0.1uF	50V	C609	1-124-994-11	ELECT 100uF	20% 10V
C307	1-136-161-00	FILM 0.047uF	5% 50V	C610	1-124-994-11	ELECT 100uF	20% 10V
C308	1-161-374-11	CERAMIC 0.0015uF	20% 50V	C611	1-124-994-11	ELECT 100uF	20% 10V
C309	1-162-306-11	CERAMIC 0.01uF	20% 16V	C613	1-136-165-00	FILM 0.1uF	5% 50V
C310	1-126-043-11	ELECT 0.47uF	20% 50V	C621	1-162-285-31	CERAMIC 180PF	10% 50V
C311	1-126-163-11	ELECT 4.7uF	20% 50V	C622	1-162-285-31	CERAMIC 180PF	10% 50V
C312	1-162-290-31	CERAMIC 470PF	10% 50V	C623	1-162-286-31	CERAMIC 220PF	10% 50V
C313	1-124-994-11	ELECT 100uF	20% 10V	C624	1-162-286-31	CERAMIC 220PF	10% 50V
C314	1-164-159-11	CERAMIC 0.1uF	50V	C625	1-106-359-00	MYLAR 4700PF	5% 200V
C317	1-164-159-11	CERAMIC 0.1uF	50V	C626	1-106-343-00	MYLAR 1000PF	5% 200V
C318	1-164-159-11	CERAMIC 0.1uF	50V	C627	1-124-910-11	ELECT 47uF	20% 50V
C319	1-162-208-31	CERAMIC 24PF	5% 50V	< CONNECTOR >			
C320	1-162-199-31	CERAMIC 10PF	5% 50V	CN221	* 1-564-510-11	PLUG, CONNECTOR 7P	
C321	1-162-199-31	CERAMIC 10PF	5% 50V	CN356	* 1-568-834-11	SOCKET, CONNECTOR 15P	
C322	1-124-994-11	ELECT 100uF	20% 10V	CN357	* 1-564-711-11	PIN, CONNECTOR (SMALL TYPE) 9P	
C323	1-162-806-11	CERAMIC 0.1uF	10% 50V	CN359	* 1-568-822-11	SOCKET, CONNECTOR 22P	
C331	1-164-159-11	CERAMIC 0.1uF	50V	CN360	* 1-568-955-11	PIN, CONNECTOR 6P	
C332	1-162-205-31	CERAMIC 18PF	5% 50V	CN391	* 1-564-339-00	PIN, CONNECTOR 5P	
C447	1-164-159-11	CERAMIC 0.1uF	50V	< DIODE >			
C501	1-136-165-00	FILM 0.1uF	5% 50V	D201	8-719-200-82	DIODE 11ES2	
C502	1-136-165-00	FILM 0.1uF	5% 50V	D202	8-719-200-82	DIODE 11ES2	
C503	1-136-165-00	FILM 0.1uF	5% 50V	D203	8-719-200-82	DIODE 11ES2	
C504	1-162-806-11	CERAMIC 0.1uF	10% 50V	D204	8-719-200-82	DIODE 11ES2	
C505	1-136-165-00	FILM 0.1uF	5% 50V	D205	8-719-200-82	DIODE 11ES2	
C506	1-136-165-00	FILM 0.1uF	5% 50V	D206	8-719-987-63	DIODE 1N4148M	
C507	1-136-165-00	FILM 0.1uF	5% 50V	D207	8-719-109-85	DIODE RD5.1ES-B2	
C509	1-124-994-11	ELECT 100uF	20% 10V	D209	8-719-110-08	DIODE RD8.2ES-B2	
C510	1-124-994-11	ELECT 100uF	20% 10V	D210	8-719-987-63	DIODE 1N4148M	
C511	1-124-994-11	ELECT 100uF	20% 10V	D211	8-719-110-08	DIODE RD8.2ES-B2	
C513	1-136-165-00	FILM 0.1uF	5% 50V	D212	8-719-114-27	DIODE RD4.7JS-B3	
C521	1-162-285-31	CERAMIC 180PF	10% 50V	D213	8-719-114-27	DIODE RD4.7JS-B3	
C522	1-162-285-31	CERAMIC 180PF	10% 50V	D214	8-719-210-21	DIODE 11EQS04	
C523	1-162-286-31	CERAMIC 220PF	10% 50V	D225	8-719-934-31	DIODE HZS36-3L	
C524	1-162-286-31	CERAMIC 220PF	10% 50V	D322	8-719-987-63	DIODE 1N4148M	
C525	1-106-359-00	MYLAR 4700PF	5% 200V	D391	8-719-109-89	DIODE RD5.6ES-B2	
C526	1-106-343-00	MYLAR 1000PF	5% 200V	D501	8-719-987-63	DIODE 1N4148M	
C527	1-124-910-11	ELECT 47uF	20% 50V	D502	8-719-987-63	DIODE 1N4148M	
C530	1-164-159-11	CERAMIC 0.1uF	50V	D601	8-719-987-63	DIODE 1N4148M	
C551	1-136-165-00	FILM 0.1uF	5% 50V	D602	8-719-987-63	DIODE 1N4148M	
C552	1-136-165-00	FILM 0.1uF	5% 50V				

MAIN

Ref. No.	Part No.	Description	Remark	Ref. No.	Part No.	Description	Remark
< IC >				< RESISTOR >			
IC201	8-759-630-21	IC M5290P-16		R201	1-249-425-11	CARBON 4.7K	5% 1/4W
IC325	8-759-822-78	IC LC3564PML-1015		R202	1-249-425-11	CARBON 4.7K	5% 1/4W
IC326	8-759-962-08	IC BA6208		R203	1-249-424-11	CARBON 3.9K	5% 1/4W
IC327	8-759-635-50	IC M37450M8-372FP		R204	△ 1-212-869-00	FUSIBLE 33	5% 1/4W F
IC328	8-752-337-26	IC CXD2500AQ		R205	1-249-435-11	CARBON 33K	5% 1/4W
IC329	8-759-917-18	IC SN74HCU04AN		R206	1-249-413-11	CARBON 470	5% 1/4W
IC330	8-752-328-61	IC CXD1244S		R208	1-249-425-11	CARBON 4.7K	5% 1/4W
IC331	8-752-339-86	IC CXD2557M		R213	1-249-417-11	CARBON 1K	5% 1/4W
IC332	8-759-917-18	IC SN74HCU04AN		R214	1-249-417-11	CARBON 1K	5% 1/4W
IC350	8-749-921-20	IC T-1550		R216	1-249-417-11	CARBON 1K	5% 1/4W
IC391	8-759-633-65	IC M54641L		R219	1-249-393-11	CARBON 10	5% 1/4W
IC501	8-752-335-53	IC CXD2552Q-3		R220	1-249-405-11	CARBON 100	5% 1/4W
IC551	8-759-982-03	IC RC5532DD		R221	1-249-406-11	CARBON 120	5% 1/4W
IC553	8-759-981-85	IC RC4556D		R222	1-249-435-11	CARBON 33K	5% 1/4W
IC601	8-752-335-53	IC CXD2552Q-3		R225	1-249-441-11	CARBON 100K	5% 1/4W
IC651	8-759-982-03	IC RC5532DD		R301	1-249-411-11	CARBON 330	5% 1/4W
< JACK >				R302	1-249-429-11	CARBON 10K	5% 1/4W
J361	1-569-443-21	JACK. PIN 4P (LINE OUT)		R304	1-249-429-11	CARBON 10K	5% 1/4W
< COIL >				R305	1-249-429-11	CARBON 10K	5% 1/4W
L301	1-410-509-11	INDUCTOR 10uH		R306	1-249-429-11	CARBON 10K	5% 1/4W
L302	1-412-473-21	INDUCTOR 0uH		R307	1-249-429-11	CARBON 10K	5% 1/4W
L320	1-408-403-00	INDUCTOR 3.3uH		R308	1-249-429-11	CARBON 10K	5% 1/4W
< TRANSISTOR >				R309	1-249-429-11	CARBON 10K	5% 1/4W
Q204	8-729-900-61	TRANSISTOR DTA114ES		R310	1-249-429-11	CARBON 10K	5% 1/4W
Q206	8-729-111-67	TRANSISTOR 2SB1094L		R311	1-249-429-11	CARBON 10K	5% 1/4W
Q207	8-729-140-96	TRANSISTOR 2SD774-34		R312	1-249-429-11	CARBON 10K	5% 1/4W
Q208	8-729-140-96	TRANSISTOR 2SD774-34		R313	1-249-429-11	CARBON 10K	5% 1/4W
Q209	8-729-119-78	TRANSISTOR 2SC2785-HFE		R314	1-249-429-11	CARBON 10K	5% 1/4W
Q210	8-729-111-67	TRANSISTOR 2SB1094L		R315	1-249-429-11	CARBON 10K	5% 1/4W
Q217	8-729-216-13	TRANSISTOR 2SK161GR		R316	1-249-429-11	CARBON 10K	5% 1/4W
Q218	8-729-905-67	TRANSISTOR 2SD1944-K		R317	1-249-429-11	CARBON 10K	5% 1/4W
Q223	8-729-119-76	TRANSISTOR 2SA1175-HFE		R318	1-249-429-11	CARBON 10K	5% 1/4W
Q323	8-729-900-80	TRANSISTOR DTC114ES		R319	1-247-903-00	CARBON 1M	5% 1/4W
Q501	8-729-900-61	TRANSISTOR DTA114ES		R320	1-249-417-11	CARBON 1K	5% 1/4W
Q502	8-729-201-05	TRANSISTOR 2SC2878-B		R321	1-249-417-11	CARBON 1K	5% 1/4W
Q503	8-729-900-74	TRANSISTOR DTC143TS		R322	1-249-417-11	CARBON 1K	5% 1/4W
Q504	8-729-900-74	TRANSISTOR DTC143TS		R323	1-249-417-11	CARBON 1K	5% 1/4W
Q601	8-729-900-61	TRANSISTOR DTA114ES		R324	1-249-417-11	CARBON 1K	5% 1/4W
Q602	8-729-201-05	TRANSISTOR 2SC2878-B		R325	1-249-417-11	CARBON 1K	5% 1/4W
Q603	8-729-900-74	TRANSISTOR DTC143TS		R329	1-249-411-11	CARBON 330	5% 1/4W
Q604	8-729-900-74	TRANSISTOR DTC143TS		R330	1-249-417-11	CARBON 1K	5% 1/4W
				R331	1-249-417-11	CARBON 1K	5% 1/4W
				R332	1-249-417-11	CARBON 1K	5% 1/4W
				R333	1-249-441-11	CARBON 100K	5% 1/4W
				R334	1-249-429-11	CARBON 10K	5% 1/4W

Note:
The components identified by mark △ or dotted line with mark △ are critical for safety. Replace only with part number specified.

Note:
Les composants identifiés par une marque △ sont critiques pour la sécurité. Ne les remplacer que par une pièce portant le numéro spécifié.

MAIN

SWITCH

L. MOTOR

AC SW

Ref. No.	Part No.	Description	Remark
R335	1-249-423-11	CARBON	3.3K 5% 1/4W
R336	1-249-423-11	CARBON	3.3K 5% 1/4W
R337	1-249-429-11	CARBON	10K 5% 1/4W
R339	1-249-409-11	CARBON	220 5% 1/4W
R340	1-249-413-11	CARBON	470 5% 1/4W
R341	1-249-413-11	CARBON	470 5% 1/4W
R342	1-249-417-11	CARBON	1K 5% 1/4W
R343	1-249-413-11	CARBON	470 5% 1/4W
R344	1-249-413-11	CARBON	470 5% 1/4W
R345	1-249-413-11	CARBON	470 5% 1/4W
R346	1-249-413-11	CARBON	470 5% 1/4W
R347	1-249-417-11	CARBON	1K 5% 1/4W
R348	1-249-428-11	CARBON	8.2K 5% 1/4W
R349	1-249-436-11	CARBON	39K 5% 1/4W
R350	1-249-428-11	CARBON	8.2K 5% 1/4W
R351	1-249-436-11	CARBON	39K 5% 1/4W
R352	1-249-429-11	CARBON	10K 5% 1/4W
R355	1-249-393-11	CARBON	10 5% 1/4W
R391	1-249-429-11	CARBON	10K 5% 1/4W
R392	1-249-429-11	CARBON	10K 5% 1/4W
R521	1-215-443-00	METAL	8.2K 1% 1/6W
R522	1-215-443-00	METAL	8.2K 1% 1/6W
R523	1-215-443-00	METAL	8.2K 1% 1/6W
R524	1-215-443-00	METAL	8.2K 1% 1/6W
R525	1-215-436-00	METAL	4.3K 1% 1/6W
R526	1-215-447-00	METAL	12K 1% 1/6W
R527	1-215-436-00	METAL	4.3K 1% 1/6W
R528	1-215-447-00	METAL	12K 1% 1/6W
R529	1-249-419-11	CARBON	1.5K 5% 1/4W
R530	1-249-419-11	CARBON	1.5K 5% 1/4W
R531	1-249-409-11	CARBON	220 5% 1/4W
R532	1-249-409-11	CARBON	220 5% 1/4W
R533	1-249-409-11	CARBON	220 5% 1/4W
R534	1-247-891-00	CARBON	330K 5% 1/4W
R535	1-249-393-11	CARBON	10 5% 1/4W
R536	1-249-409-11	CARBON	220 5% 1/4W
R537	1-247-901-11	CARBON	820K 5% 1/4W
R551	1-249-435-11	CARBON	33K 5% 1/4W
R552	1-249-435-11	CARBON	33K 5% 1/4W
R553	1-249-435-11	CARBON	33K 5% 1/4W
R554	1-249-435-11	CARBON	33K 5% 1/4W
R555	1-249-425-11	CARBON	4.7K 5% 1/4W
R556	1-249-425-11	CARBON	4.7K 5% 1/4W
R557	1-249-435-11	CARBON	33K 5% 1/4W
R558	1-249-435-11	CARBON	33K 5% 1/4W
R621	1-215-443-00	METAL	8.2K 1% 1/6W
R622	1-215-443-00	METAL	8.2K 1% 1/6W
R623	1-215-443-00	METAL	8.2K 1% 1/6W
R624	1-215-443-00	METAL	8.2K 1% 1/6W

Ref. No.	Part No.	Description	Remark
R625	1-215-436-00	METAL	4.3K 1% 1/6W
R626	1-215-447-00	METAL	12K 1% 1/6W
R627	1-215-436-00	METAL	4.3K 1% 1/6W
R628	1-215-447-00	METAL	12K 1% 1/6W
R629	1-249-419-11	CARBON	1.5K 5% 1/4W
R630	1-249-419-11	CARBON	1.5K 5% 1/4W
R631	1-249-409-11	CARBON	220 5% 1/4W
R632	1-249-409-11	CARBON	220 5% 1/4W
R633	1-249-409-11	CARBON	220 5% 1/4W
R634	1-247-891-00	CARBON	330K 5% 1/4W
R635	1-249-393-11	CARBON	10 5% 1/4W
R636	1-249-409-11	CARBON	220 5% 1/4W
R637	1-247-895-00	CARBON	470K 5% 1/4W
< CRYSTAL >			
X331	1-579-161-11	VIBRATOR, CRYSTAL (45MHz)	
X355	1-577-377-11	VIBRATOR, CERAMIC (10MHz)	

* 1-632-974-11 SWITCH BOARD			

* 1-632-975-11 L. MOTOR BOARD			

< CAPACITOR >			
C001	1-136-157-00	FILM	0.022uF 5% 50V
< RESISTOR >			
R001	△ 1-215-880-00	METAL OXIDE	10 5% 2W F
R002	△ 1-215-880-00	METAL OXIDE	10 5% 2W F
< SWITCH >			
S001	1-571-736-11	SWITCH, LEAF (IN)	
S002	1-571-736-11	SWITCH, LEAF (OUT)	

* 1-639-215-11 AC SW BOARD			

< CAPACITOR >			
C701	1-161-744-00	CERAMIC	0.01MF 400V
< CONNECTOR >			
CN701	* 1-564-321-00	PIN, CONNECTOR 2P	
< SWITCH >			
S701	△ 1-570-156-11	SWITCH, PUSH (AC POWER) (1 KEY) (POWER)	

Note:
The components identified by mark Δ or dotted line with mark Δ are critical for safety. Replace only with part number specified.

Note:
Les composants identifiés par une marque Δ sont critiques pour la sécurité. Ne les remplacer que par une pièce portant le numéro spécifié.

TRANSFORMER

REMOTE CONTROL VOL

TIMER SW

Ref. No.	Part No.	Description	Remark
	* 1-639-212-11	TRANSFORMER BOARD *****	
		< CAPACITOR >	
C702	1-164-159-11	CERAMIC 0.1uF	50V
		< CONNECTOR >	
CN701	* 1-564-321-00	PIN, CONNECTOR 2P	
CN703	* 1-564-709-11	PIN, CONNECTOR (SMALL TYPE) 7P	
CN702	* 1-580-230-11	PIN, CONNECTOR (PC BOARD) 3P	
		< SWITCH >	
SW702	1-571-722-11	SWITCH, VOLTAGE SELECTION (VOLTAGE SELECTOR) (E)	

	* 1-639-211-11	REMOTE CONTROL VOL BOARD *****	
		< CAPACITOR >	
C405	1-164-159-11	CERAMIC 0.1uF	50V
		< CONNECTOR >	
CN409	* 1-568-955-11	PIN, CONNECTOR 6P	
CN447	* 1-564-707-11	PIN, CONNECTOR (SMALL TYPE) 5P	
		< VARIABLE RESISTOR >	
RV405	1-241-321-11	RES. VAR, CARBON 10KX3 (LINE OUT PHONE LEVEL)	

	* 1-639-214-11	TIMER SW BOARD *****	
		< SWITCH >	
S476	1-570-157-51	SWITCH, SLIDE (TIMER)	

Ref. No.	Part No.	Description	Remark
		MISCELLANEOUS *****	
72	1-535-896-11	JUMPER, FILM (WITH TERMINAL)	
73	1-590-882-11	WIRE, FLAT TYPE (15 CORE)	
103	1-590-883-11	WIRE, FLAT TYPE (22 CORE)	
110	1-559-583-21	CORD, POWER (US, Canadian)	
112	1-558-181-21	CORD, POWER (E)	
113	1-559-555-21	CORD, POWER (UK)	
114	1-558-568-21	CORD, POWER (AEP)	
115	1-575-379-21	CORD, POWER (AUS)	
201	8-848-144-11	DEVICE, OPTICAL KSS-240A	
202	1-575-001-11	WIRE, FLAT TYPE (12 CORE)	
M001	A-4604-347-A	MOTOR (L) ASSY	
M101	X-4917-523-3	MOTOR ASSY (SPINDLE)	
M102	X-4917-504-1	MOTOR ASSY (SLED)	
Q206	8-729-111-67	TRANSISTOR 2SB1274SA-R	
RV405	1-241-321-11	RES. VAR, CARBON 10KX3 (LINE OUT PHONE LEVEL)	
S1015	1-572-085-11	SWITCH, LEAF (LIMIT IN)	
S7013	1-570-156-11	SWITCH, PUSH (AC OIWER) (1 KEY) (POWER)	
T901	1-449-921-11	TRANSFORMER, POWER (US, Canadian)	
T901	1-449-922-11	TRANSFORMER, POWER (UK, AEP, AUS)	
T901	1-449-923-11	TRANSFORMER, POWER (E)	

		ACCESSORY & PACKING MATERIAL *****	
	1-465-593-11	COMMANDER, REMOTE	
	1-558-271-11	CORD, CONNECTION	
	1-569-007-11	ADAPTOR, CONVERSION 2P (E)	
	3-704-343-01	SHEET (STANDARD), PROTECTION	
*	3-707-584-01	COVER, BATTERY	
	3-752-484-11	MANUAL, INSTRUCTION (ENGLISH, FRENCH, SPANISH, PORTUGUESE) (UK, E, AEP, Canadian)	
	3-752-484-21	MANUAL, INSTRUCTION (ENGLISH) (US, AUS)	
	3-752-484-41	MANUAL, INSTRUCTION (GERMAN, DUTCH, SWEDISH, ITALIAN) (AEP)	
*	3-795-629-11	INSTRUCTION	
*	4-934-098-01	STOPPER, DISK TABLE	
*	4-942-117-21	INDIVIDUAL CARTON	
*	4-944-761-01	CUSHION	

		HARDWARE LIST *****	
# 1	7-621-996-24	BOLT 2.6X4, HEXAGON SOCKET	
# 2	7-682-548-09	SCREW +BVTT 3X8 (S)	
# 3	7-682-548-04	SCREW +BVTT 3X8 (S)	
# 4	7-685-647-79	SCREW +P 3X10 TYPE2 SLIT	
# 5	7-621-770-67	SCREW +BVTT 2.6X6 (S)	
# 6	7-624-105-04	STOP RING 2.3, TYPE -E	
# 7	7-682-544-04	SCREW +P 3X3	
# 8	7-621-775-10	SCREW +BVTT 2.6X4 (S)	
# 9	7-621-255-15	SCREW +P 2X3	
# 10	7-685-134-19	SCREW +BTP 2.6X8 TYPE2 N-S	
# 11	7-685-646-79	SCREW +BVTP 3X8 TYPE2 N-S	

Note:
The components identified by mark Δ or dotted line with mark Δ are critical for safety. Replace only with part number specified.

Note:
Les composants identifiés par une marque Δ sont critiques pour la sécurité. Ne les remplacer que par une pièce portant le numéro spécifié.

CDP-X222ES

SONY[®] SERVICE MANUAL

US Model
Canadian Model
AEP Model
UK Model
E Model
Australian Model

SUPPLEMENT-1

File this supplement with the service manual.

- | |
|---------------------------------------------------------------------------------------------------------------------------------------------------------------------------------------------------------------------------------------|
| <ol style="list-style-type: none">1. BLOCK DIAGRAM2. PIN DESCRIPTION<ul style="list-style-type: none">● IC327 Mechanism Controller● IC401 Master Controller |
|---------------------------------------------------------------------------------------------------------------------------------------------------------------------------------------------------------------------------------------|

1. BLOCK DIAGRAM

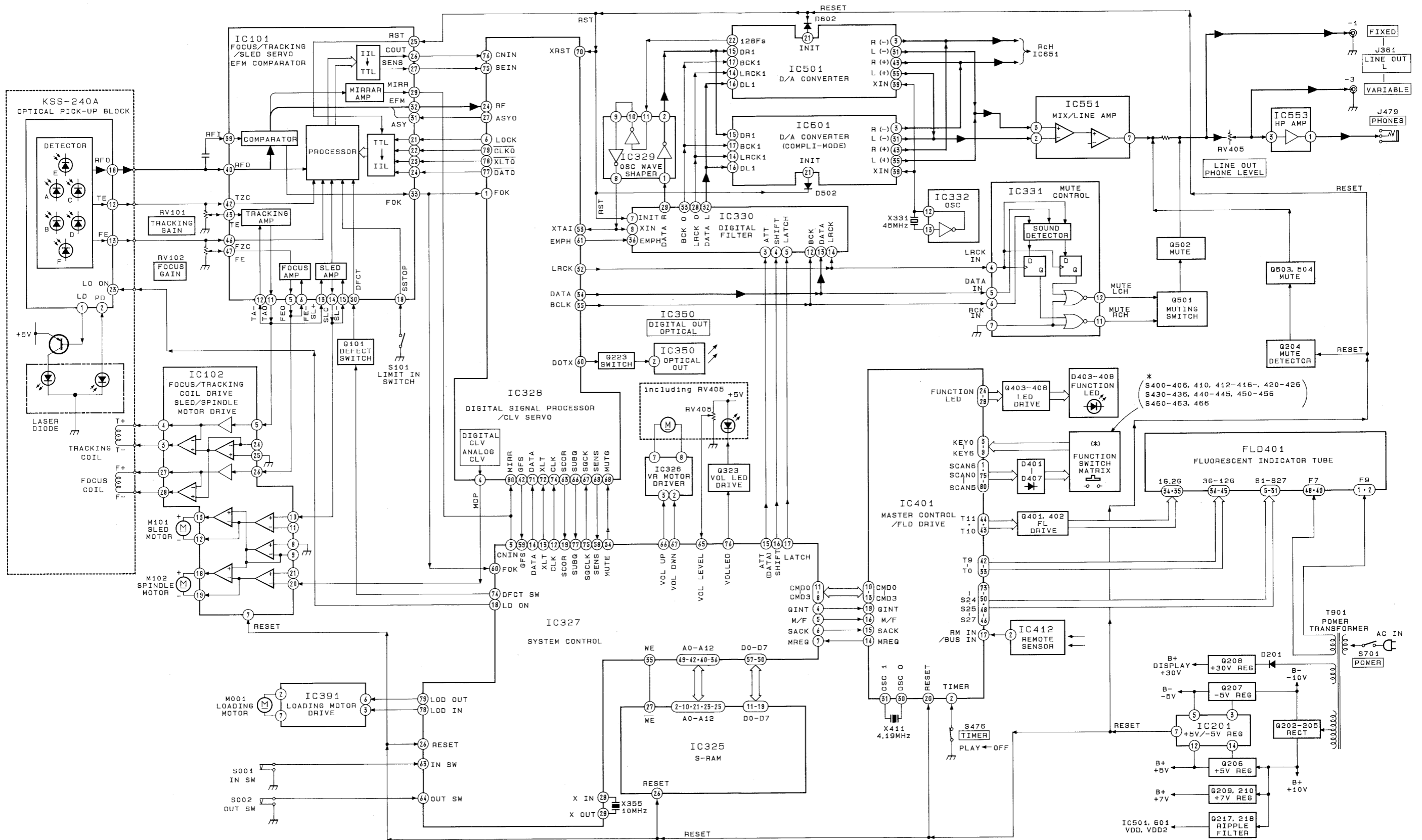

2. PIN DESCRIPTION
● IC327 MECHANISM CONTROLLER (M37450M8-372FP)

Functions effected by the captioned controller include IC101 (RF signal processing, servo), IC328 (DSP), IC330 (digital filter, custom file), loading control and volume motor control, data exchange with IC401 (master controller).

Pin No.	Pin Name	I / O	Description	Connect to the following parts.
1	NC	-	Not used (open)	
2	DIRCON	-	Not used (open)	
3	CNIN	I	Signal input for track jump count.	IC101 (SSP)
4	QINT	O	Interrupt output, the pulse output's when the data proceed to master controller	IC401
5	M/F	I/O	Command select I/O terminal. Custom file data : "L" Subcode data : "H"	IC401
6	SACK	O	Data transfer acknowledge signal output. The pulse output's when the data received.	IC401
7	MREQ	I	Command request input from master controller.	IC401
8 - 11	CMD3 - 0	I/O	Control command I/O.	IC401
12	CLK	O	Data transfer clock output.	IC328 (DSP), IC101 (SSP)
13	XLT	O	Serial data latch signal output.	IC328 (DSP), IC101 (SSP)
14	DATA	O	Serial data output	IC328 (DSP), IC101 (SSP)
15	ATT (DATA)	O	Serial data output for attenuate control	IC330 (D/F)
16	SHIFT (CLK)	O	Data transfer clock output	IC330 (D/F)
17	LATCH	O	Data latch signal output	IC330 (D/F)
18	LDON	O	Laser diode ON/OFF select output of optical pick-up. "H" : ON	IC101 (SSP)
19	SCOR	±	Subcode sync signal S0 + S1 detection input.	IC328 (DSP)
20	WR	O	} Not used (open)	
21	RD	O		
22	R/W	O		
23	SYNC	O		
24	RESET OUT	O		
25	CN Vss	I	Operation mode control signal input of processor.	IC201 (POWER)
26	RESET	I	Reset input. "L" : reset	
27	NC	-	Not used (open)	
28	XIN	I	Clock input (1MHz)	
29	XOUT	O	Clock output	X355
30, 31	NC	-	Not used (open)	X355
32	Vss	-	Power supply (GND)	
33	AMUTE	O	Analog muting control output. Not in use with this model (pull up)	
34	MUTE	O	Muting control output. "H" : Mute	
35	WE	O	Write enable output to custom file memory.	IC325 (RAM)
36 - 40	A12 - 8	O	Address bus output to custom file memory.	IC325 (RAM)
41	NC	-	Not used (open)	
42 - 49	A7 - 0	O	Address bus output to custom file memory.	IC325 (RAM)

Pin No.	Pin Name	I/O	Description	Connect to the following parts.
50 - 57	D7 - 0	I/O	Address bus I/O to custom file memory.	IC325 (RAM)
58	SENS	I	SENS input	IC101 (SSP), IC328 (DSP)
59	GFS	I	Frame sync signal clock status input. "H" : OK	IC328 (DSP)
60	FOK	I	Focus OK signal input	IC101 (SSP)
61	ADJ	I	Test mode input. Upon "L", GFS checking is disabled while continuously rotating the spindle no matter whether frame sync is issued during PLAY, PAUSE or SEARCH and it is not effected the focus gain down.	
62	AFADJ	I	Test mode input. Various test operations are effected upon "L" after turning ON the POWER.	
63	IN SW	I	Loading in switch input. Disc table closed : "L".	S001
64	OUT SW	I	Loading out switch input. Disc table opened : "L".	S002
65	V LEVEL	I	Location detector input (analog) of phone level volume.	RV405
66	VOL UP	O	Volume motor control output. Volume up : "H" *1	IC326 (RV405)
67	VOL DWN	O	Volume motor control output. Volume down : "L" *1	IC326 (RV405)
68	D/A Vref	I	D/A converter reference voltage input (+5V).	
69	A/D Vref	I	A/D converter reference voltage input (+5V).	
70	AVss	-	Analog power supply (GND)	
71	AVcc	-	Analog power supply (+5V)	
72	Vcc	-	Power supply (+5V)	
73	Vss	-	Power supply (GND)	
74	DFCT SW	O	ON/OFF selector output for DEFECT circuit. The disc flaw detection circuit is turned off ("H") when focus-search.	IC101 (SSP)
75	SQ CLK		Subcode Q data readout clock output.	IC328 (DSP)
76	VOL LED	O	Volume LED ON/OFF control output. "H" : LED ON	Q323 (RV405)
77	SUBQ	I	Subcode Q data input.	IC328 (DSP)
78	LOD IN	O	Output to rotate the loading motor in the loading out direction. *2	IC391 (M001)
79	LOD OUT	O	Output to rotate the loading motor in the loading in direction. *2	IC391 (M001)
80	NC	-	Not used (open)	

*1 Volume motor control

	UP	DOWN	BRAKE
VOL UP (66)	H	L	H
VOL DOWN (67)	L	H	H

*2 Loading motor control

	IN	OUT	BRAKE
LOD IN (78)	H	L	H
LOD OUT (79)	L	H	H

● IC401 MASTER CONTROLLER (MSC62408-015GS-V1K)

In charge of displaying the FL tube, keying in and remote control signal input, data exchanges with the IC327 (mechanism controller) in 4-bit parallel mode.

Pin No.	Pin Name	I/O	Description	Connect to the following parts.
2	TIMER	I	Timer switch input. "H" : PLAY, "L" : OFF	S476
3 - 9	KEY0 - 6	I	Key matrix input.	KEY MATRIX
10 - 13	CMD0 - 3	I/O	Control command I/O terminals	IC327
14	M. REQ	O	Command request input to mechanism controller	IC327
15	S. ACK	I	Data transfer acknowledge signal input	IC327
16	M/F	I/O	Command select I/O terminal	IC327
17	RMIN	I	Remote control signal input	IC412
18	-	-	Not used (GND)	
19	Q. INT	O	Interrupt output. The pulse proceed when mechanism controller (IC327) received the data.	IC327
20	RESET	I	Reset input. "L" : reset	IC201 (POWER)
21	TEST	I	Not used (GND)	
22	BUS OUT	O	Not used (open)	
23	TEST	I	Not used (pull up)	
24	INDEX	O	} Panel LED ON/OFF control output. "H" : LED ON	Q403 - 408 (D408 - 412)
25	PGM	O		
26	SHUF	O		
27	CONT	O		
28	PAUSE	O		
29	PLAY	O		
30	OSCI	I	Clock input (4.19MHz)	X411
31	OSCO	O	Clock output	X411
32	GND	-	Ground	
33 - 44	T0 - 11	O	Output port for grid of FL tube.	FLD401
45	N. C	-	Not used (open)	
46 - 48	S1 - 3	O	Output port for segment of FL tube.	FLD401
49	VFLT	-	Power supply port for built-in Fl tube controller. (+37V)	
50 - 73	S4 - 27	O	Output port for segment of FL tube.	FLD401
74	VDD	-	Power supply port (+5V)	
75 - 80	SCAN0 - 5	O	Key scan output	KEY MATRIX

CDP-X222ES

SONY SERVICE MANUAL

US Model
Canadian Model
AEP Model
UK Model
E Model
Australian Model

CORRECTION-1

Correct your service manual as shown below.

 : indicates corrected portion.

Page	INCORRECT			CORRECT	
	No.	Part No.	Description	Part No.	Description
23	178	_____	not supplied _____	4-927-641-24	CHASSIS(OUTSERT) MECHANICAL
<p>4-4. CD MECHANISM BLOCK (CDM11J-5BD3)</p> 